



Komodo CoaXPress Frame Grabber Hardware Reference and Installation Guide

(Part-No. KY-FGK-XXX)

January 2015

International Distributors

sky blue
microsystems

Sky Blue Microsystems GmbH
Geisenhausenerstr. 18
81379 Munich, Germany
+49 89 780 2970, info@skyblue.de
www.skyblue.de

ZERIF
TECHNOLOGIES LTD.
A SKY BLUE COMPANY, FOUNDED 1999

In Great Britain:
Zerif Technologies Ltd.
Winnington House, 2 Woodberry Grove
Finchley, London N12 0DR
+44 115 855 7883, info@zerif.co.uk
www.zerif.co.uk

1	Figures and Tables	2
2	Introduction	3
2.1	Safety Precautions	3
2.2	Disclaimer.....	4
3	Key Features.....	6
3.1	Overview	6
3.2	Features.....	6
3.3	Product Applications	7
3.4	Related documents and accessories	8
4	System Description	9
4.1	Example System Block Diagram.....	9
4.2	External View of the Board.....	10
5	Mechanical Specifications	11
5.1	Essentials to get started	11
5.2	Power supplies.....	11
5.3	Mechanical dimensions	13
6	Installation and Configurations	14
6.1	Installation instructions	14
6.2	Connecting to CoaXPress output connectors	14
6.3	Komodo LEDs.....	15
6.4	Komodo Hardware Reference	16
6.5	Komodo Board Block Diagram.....	17
6.6	Video stream acquisition	18
6.7	Auxiliary Input/Output signals	18
6.8	Absolute maximum ratings.....	23
6.9	Electrical characteristics for board IO's:.....	23

Figures

FIGURE 1: COAXPRESS SYSTEM BLOCK DIAGRAM	9
FIGURE 2: KOMODO BOARD EXTERNAL VIEW	10
FIGURE 3: EXTERNAL POWER SUPPLY CONNECTOR	12
FIGURE 4: PCB MECHANICAL DIMENSIONS	13
FIGURE 5: KOMODO BOARD LED'S LOCATIONS	16
FIGURE 6: KOMODO BOARD BLOCK DIAGRAM	17
FIGURE 7: GPIO CONNECTORS LOCATION	19
FIGURE 8: GPIO CONNECTORS SCHEMATIC	20

Tables

TABLE 1: COAXPRESS LINKS STATUS LED'S	15
TABLE 2: BOARD STATUS LED'S	16
TABLE 3: J1 CONNECTOR PINOUT	21
TABLE 4: J2 CONNECTOR PINOUT	22
TABLE 5: ABSOLUTE MAXIMUM RATINGS	23
TABLE 6: ABSOLUTE MAXIMUM RATINGS FOR GPIO	23
TABLE 7: LVDS OUTPUT DC SPECIFICATIONS (DRIVER OUTPUTS)	24
TABLE 8: LVDS INPUT DC SPECIFICATIONS (RECEIVER INPUTS)	24
TABLE 9: LVTTL INPUT SPECIFICATIONS.....	24
TABLE 10: LVTTL OUTPUT SPECIFICATIONS	24
TABLE 11: TTL INPUT SPECIFICATIONS	25
TABLE 12: TTL OUTPUT SPECIFICATIONS.....	25

Revision History

Version	Date	Notes
0.1		Initial Release
0.2	15/2/15	Corrected Table 4 and Figure 8

2.1 Safety Precautions

With your *Komodo CoaXPress Frame Grabber board* in hand, please take a minute to read carefully the precautions listed below in order to prevent unnecessary injuries to you or other personnel or cause damage to property.

- **Before using the product, read these safety precautions carefully to assure correct use.**
- **These precautions contain serious safety instructions that must be observed.**
- **After reading through this manual, be sure to act upon it to prevent misuse of product.**



Caution

In the event of a failure, disconnect the power supply.

If the product is used as is, a fire or electric shock may occur. Disconnect the power supply immediately and contact our sales personnel for repair.

If an unpleasant smell or smoking occurs, disconnect the power supply.

If the product is used as is, a fire or electric shock may occur. Disconnect the power supply immediately. After verifying that no smoking is observed, contact our sales personnel for repair.

Do not disassemble, repair or modify the product.

Otherwise, a fire or electric shock may occur due to a short circuit or heat generation. For inspection, modification or repair, contact our sales personnel.

Do not touch a cooling fan.

As a cooling fan rotates in high speed, do not put your hand close to it. Otherwise, it may cause injury to persons. Never touch a rotating cooling fan.

Do not place the product on unstable locations.

Otherwise, it may drop or fall, resulting in injury to persons or failure.

If the product is dropped or damaged, do not use it as is.

Otherwise, a fire or electric shock may occur.

Do not touch the product with a metallic object.

Otherwise, a fire or electric shock may occur.

Do not place the product in dusty or humid locations or where water may splash.

Otherwise, a fire or electric shock may occur.

Do not get the product wet or touch it with a wet hand.

Otherwise, the product may break down or it may cause a fire, smoking or electric shock.

Do not touch a connector on the product (gold-plated portion).

Otherwise, the surface of a connector may be contaminated with sweat or skin oil, resulting in contact failure of a connector or it may cause a malfunction, fire or electric shock due to static electricity.

Do not use or place the product in the following locations.

- Humid and dusty locations
- Airless locations such as closet or bookshelf
- Locations which receive oily smoke or steam
- Locations close to heating equipment
- Closed inside of a car where the temperature becomes high
- Static electricity replete locations
- Locations close to water or chemicals

Otherwise, a fire, electric shock, accident or deformation may occur due to a short circuit or heat generation.

Do not place heavy things on the product.

Otherwise, the product may be damaged.

Be sure to drain static electricity from body before you touch any electronics component

The electronic circuits in your computer and the circuits on Komodo board are sensitive to static electricity and surges. Improper handling can seriously damage the circuits. In addition, do not let your clothing come in contact with the circuit boards or components.

Otherwise, the product may be damaged.

2.2 Disclaimer

This product should be used for interfacing of CoaXPress camera and acquiring of CoaXPress video streams. KAYA Instruments assumes no responsibility for any damages resulting from the use of this product for purposes other than those stated.

Even if the product is used properly, KAYA Instruments assumes no responsibility for any damages caused by the following:

- Earthquake, thunder, natural disaster or fire resulting from the use beyond our responsibility, acts caused by a third party or other accidents, the customer's willful or accidental misuse or use under other abnormal conditions.
- Secondary impact arising from use of this product or its unusable state (business interruption or others).
- Use of this product against the instructions given in this manual or malfunctions due to connection to other devices.

KAYA Instruments assumes no responsibility or liability for:

- Erasure or corruption of data arising from use of this product.
- Any consequences or other abnormalities arising from use of this product, or damage of this product not due to our responsibility or failure due to modification.

Repair of this product is carried out by replacing it on a chargeable basis, not repairing the faulty devices. However, non-chargeable replacement is offered for initial failure if such notification is received within two weeks after delivery of the product.

3.1 Overview

Komodo is best in its class *Frame Grabber* supporting CoaXPress standard. The *Komodo* is capable of receiving video streams from up to 8 CoaXPress links in single, dual, quad or octal modes. It is used for simultaneous capture from up to two quad link cameras. Each link supports standard CoaXPress bitrates up to 6.25 Gbps. This CoaXPress Frame Grabber is ideally suited for industrial, defense and aerospace Machine Vision Systems and applications. The *Komodo* can easily receive video streams on the CoaXPress links and transmit them to computer memory through the PCIe interface. This product also provides GPIO for machine control signals, such as triggers, shaft encoders, exposure control and general I/O, which can be control aside video stream acquisition.

The Komodo uses standard DIN connectors as a CoaXPress interface to the camera and standard 100 mil headers for general purpose I/O. The Frame Grabber utilizes PCIe Gen3 x8 links for communication with Host PC for video uploading and configuration.

3.2 Features

- 1 to 8 CoaXPress links support
- PCIe Gen3 x8 Half-length card
- Multi-stream support
- Camera controls and triggers
- Up to 4 re-transmit links
- Per-link LED indication on card bracket
- CoaXPress 1.1 compliant
- Power over CoaXPress with 13W per link
- Multiple Camera synchronization
- Multiple Frame Grabbers synchronization
- DIN 1.0/2.3 connectors for CoaXPress links
- GUI interface
- CoaXPress drivers for loopback function
- Supporting Windows and Linux OS
- API for developing custom applications

- Plug-ins modules for Matlab, HALCON and Labview
- GenCam compliant
- GenTL support
- Up to 18 GByte image buffer
- Data rates up to 6.25 Gpbs per link
- Transfer Rate of up to 60 Gbps
- 0°C to 50°C operating environment temperature

- Flexible machine I/O:
 - 8 TTL configurable I/Os
 - 8 LVCMOS configurable I/Os
 - 4 LVDS inputs
 - 4 LVDS outputs
 - 8 opto-isolated outputs
 - 8 opto-isolated inputs
 - 8 quadrature rotary encoders
 - Integrated strobe controller

3.3 Product Applications

- AOI
- Printing inspection
- 3D
- Broadcasting and sports analytics
- High-speed DVRs

3.4 Related documents and accessories

Documents:

- Vision Point App User Manual
- Vision Point API Reference Book
- CoaXPress standard 1.1

Accessories:

- CoaXPress cables (DIN to DIN)
- CoaXPress cables (DIN to BNC)

4.1 Example System Block Diagram

The Komodo Frame Grabber supports multiple modes of configuration and system topology. Few of these are presented in following diagrams.

Dual Camera Topology:

Two Single, Dual or Quad CoaXPress links with up to 6.25 Gb per link topology. Maximum throughput to PCIe of 55 Gb/sec.

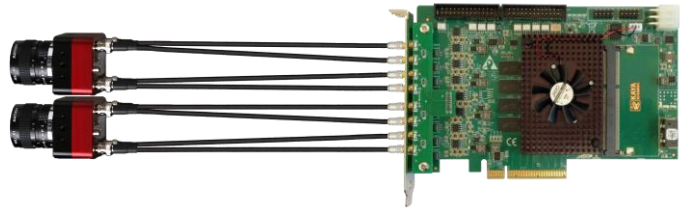

Quad Camera Topology:

Four Single or Dual CoaXPress links with up to 6.25 Gb per link topology. Maximum throughput to PCIe of 55 Gb/sec.

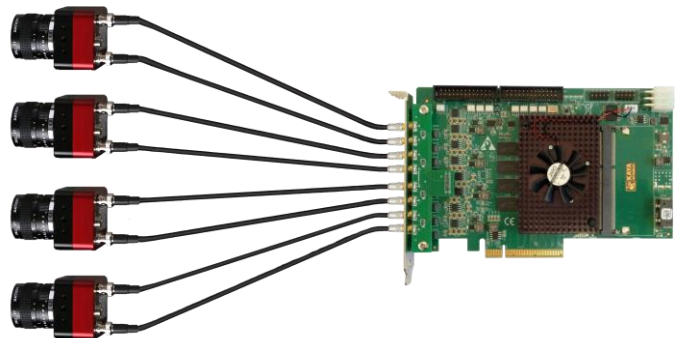

Re-transmitter topology:

Quad CoaXPress links with up to 6.25 Gb per link with re-transmitting topology. Maximum throughput to PCIe of 55 Gb/sec. Re-transmitting to other Frame Grabber at 6.25 Gb per CoaXPress link (up to 4 links)

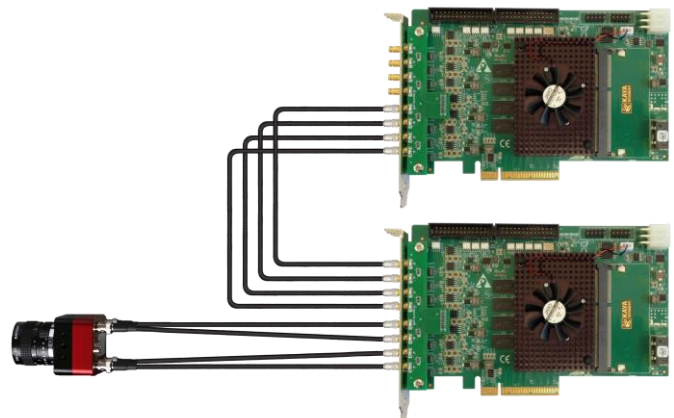

Figure 1: CoaXPress system block diagram

4.2 External View of the Board

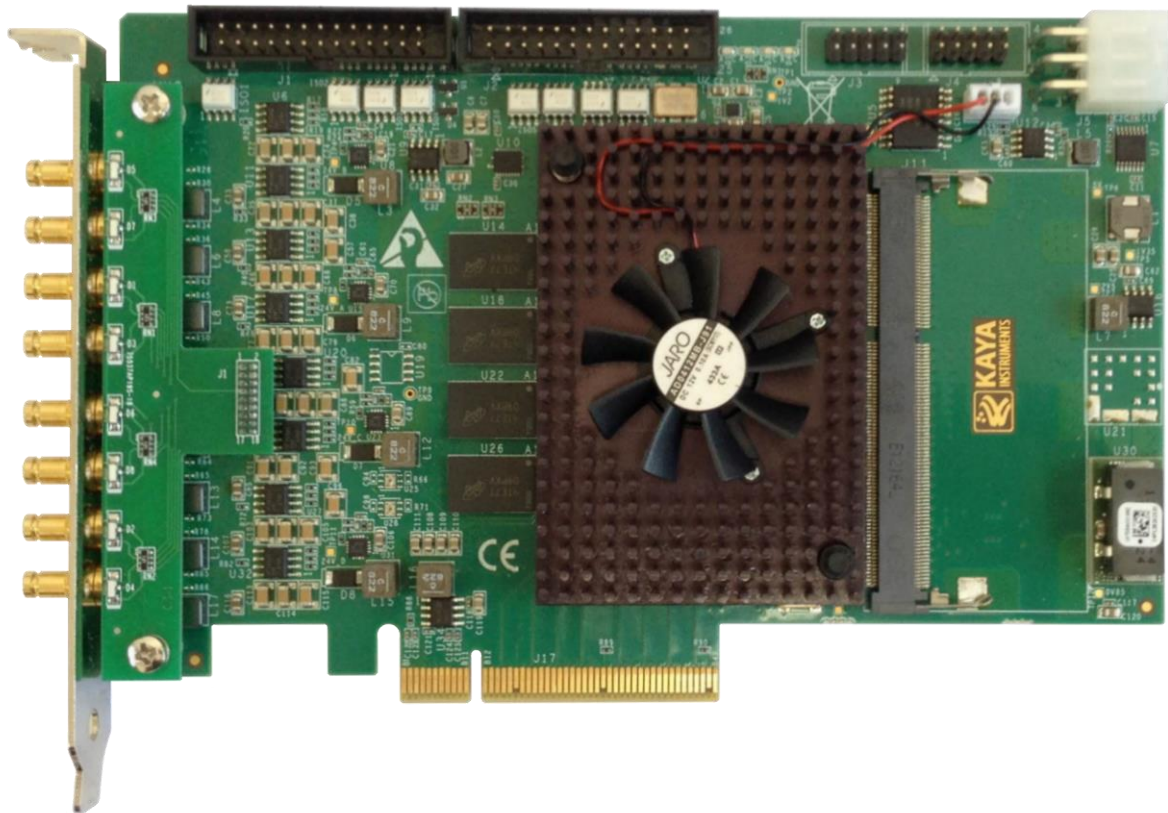

Figure 2: Komodo board external view

5.1 Essentials to get started

To begin using your Komodo Frame Grabber, you must have a computer with the following:

- ✓ Processor with an Intel 64-bit architecture, or equivalent.
- ✓ An available x4 (or x8 or x16) PCIe slot. Gen 3 support is recommended to faster data transfer.
- ✓ Vision Point Application installation

KAYA Instruments doesn't guarantee compatibility with all computers that have the above specifications. Please, consult KAYA representative for any specific issue.

5.2 Power supplies

The Komodo board receives its power from PCIe connector of the motherboard and external power supply directly from computer PSU using connector located on the right up side of the board (standard PC power connector).

According to PCIe standard 3.0, the board might consume up to 10W of power, while actual power consumption depends on usage mode and interfaces.

In order to support PoCXP feature the boards is capable of supplying up to 13W of power per each CoaXPress link.

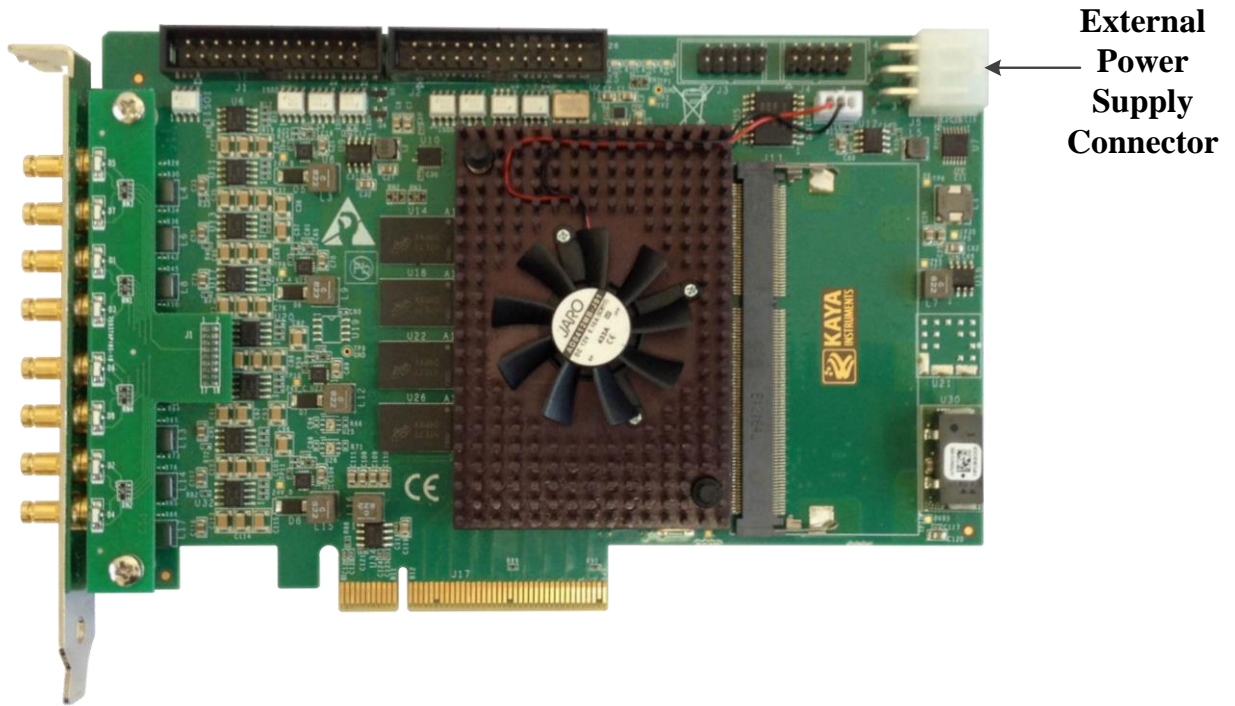

Figure 3: External Power supply connector

5.3 Mechanical dimensions

The Komodo board is a half-length PCIe card according to PCI Express Card Electromechanical Specification.

The exact board mechanical dimensions are as defined in Figure 4.

For more detailed information please, contact KAYA Instruments representative.

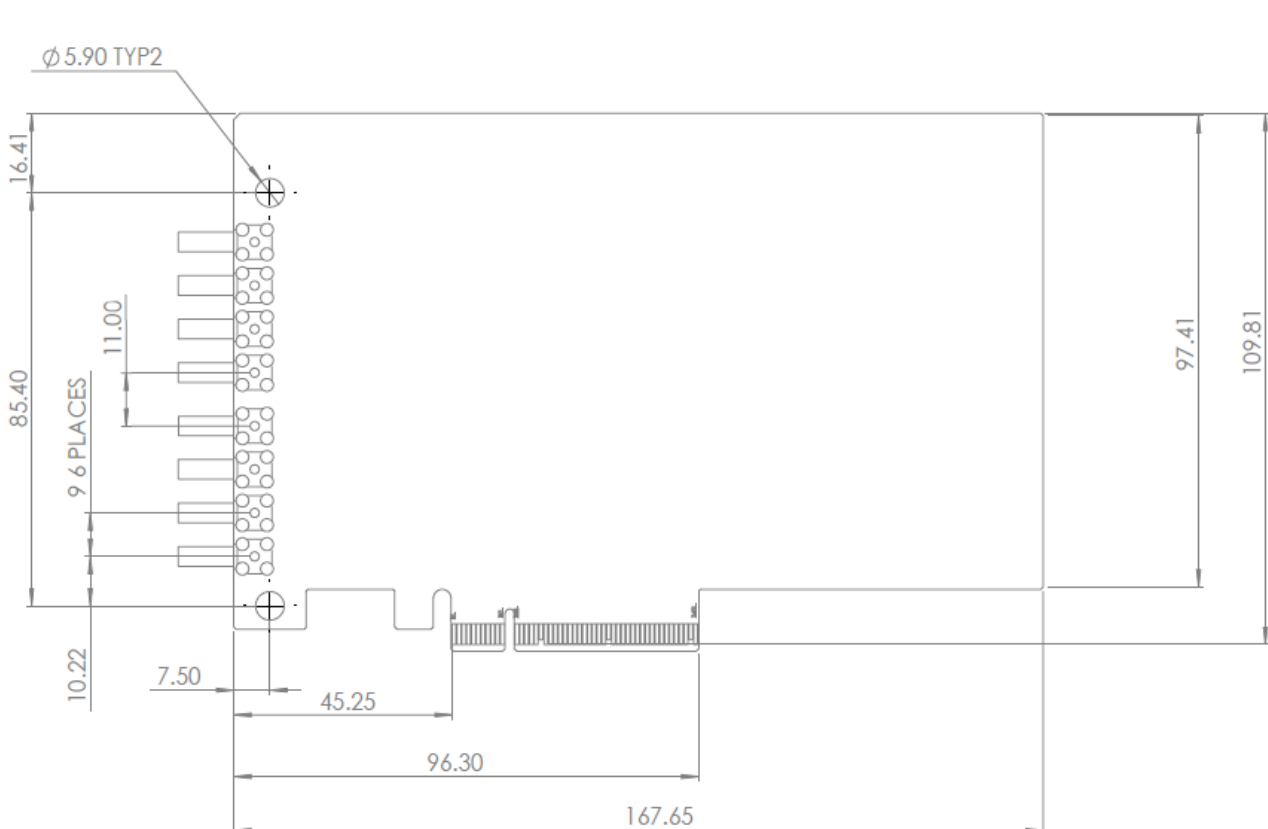

Figure 4: PCB Mechanical Dimensions

6.1 Installation instructions

Komodo board is standard PCIe card with 8 lanes connector.

It can be installed in any PCIe Gen3 connector of the motherboard with 8 lanes and up.

Note: Board should be installed before you install your software.

1. Before installing, turn off the power of the computer and its peripherals.
2. Firmly insert the Komodo board to PCIe connector of the motherboard.
3. Anchor the PCIe bracket to the computer chassis using M3 screw.
4. Verify the Komodo board inserted correctly to the PCIe slot.
5. Connect external power supply to dedicated connector (J5)
6. Power up the computer.
7. After OS is up, you will be asked to install a driver for new Multimedia Device.

At this stage, you should cancel the installation.

Under Windows and Linux the compatible drivers for Komodo board will be installed during installation of Vision Point App software.

You can install and use multiple Komodo boards in a single computer.

The number of Komodo boards that can be installed in a computer depends on the number of available PCIe slots.

6.2 Connecting to CoaXPress output connectors

Komodo board implements CoaXPress standard Din 1.0/2.3 connectors for CoaXPress interface. When attaching cables to your Komodo Frame Grabber, you must use 75 Ω coaxial cables. For best performance, it's recommended to use high quality cables, such as Belden 1694A.

Note: If you are using more than single cable to connect to the same frame grabber, the cables you use must be of the same type and length.

6.3 Komodo LEDs

Each CoaXPress link of the Frame Grabber is equipped with indication bi-color LED. The LEDs behave according to definition in section 5.4 of the CXP standard. The LEDs' different states are described in Table 1.

LED state	Description
Solid orange	System is not initialized
Slow pulse red	No camera is connected
Fast flash alternate green / orange	Connection detection in progress, PoCXP active
Fast flash orange	Connection detection in progress, PoCXP not in use
Solid red	PoCXP over-current
Solid green	Camera is connected, no data being transferred
Slow pulse orange	Camera connected. Waiting for trigger event
Fast flash green	Camera connected , data is being transferred
Slow flash alternate green / orange	Connection test packets being sent

Table 1: CoaXPress links status LED's

In addition to CoaXPress links LEDs, the Komodo Board is equipped with status LEDs.

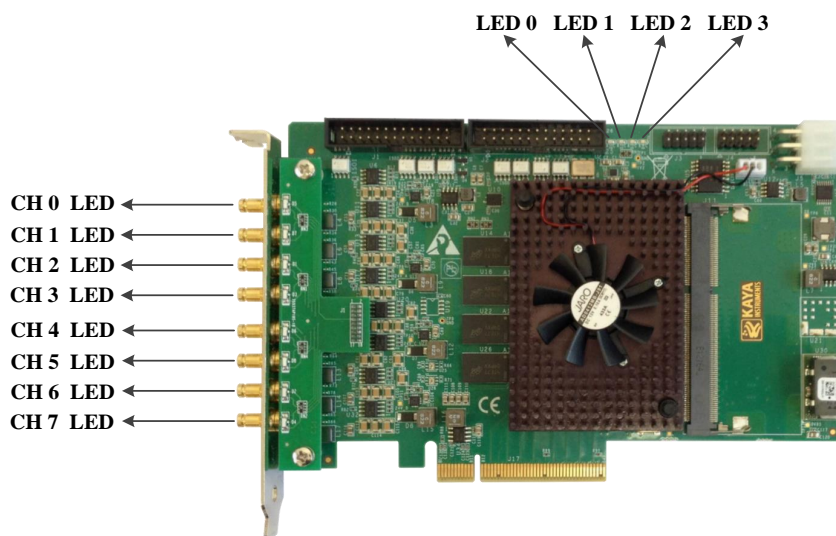

Figure 5: Komodo Board LED's locations

Board Status LEDs functionality is described in Table 2:

LED #	Description
LED 0	Alive led. Blinks when the board receives clock from PCIe
LED 1	PCIe L0 state. When lit, indicates that the PCIe interface is powered up at active state.
LED 2	Gen3 PCIe indicator. When lit indicates that PCIe is working as Gen3. When not lit the boards works either as PCIe Gen1 or Gen2
LED 3	Lane's indicator. When lit, indicates that all 8 PCIe lanes are up. If not lit, one or four lanes are up.

Table 2: Board status LED's

6.4 Komodo Hardware Reference

This chapter provides information on Komodo board hardware. It covers architecture, features and pin assignments for various connectors.

6.5 Komodo Board Block Diagram

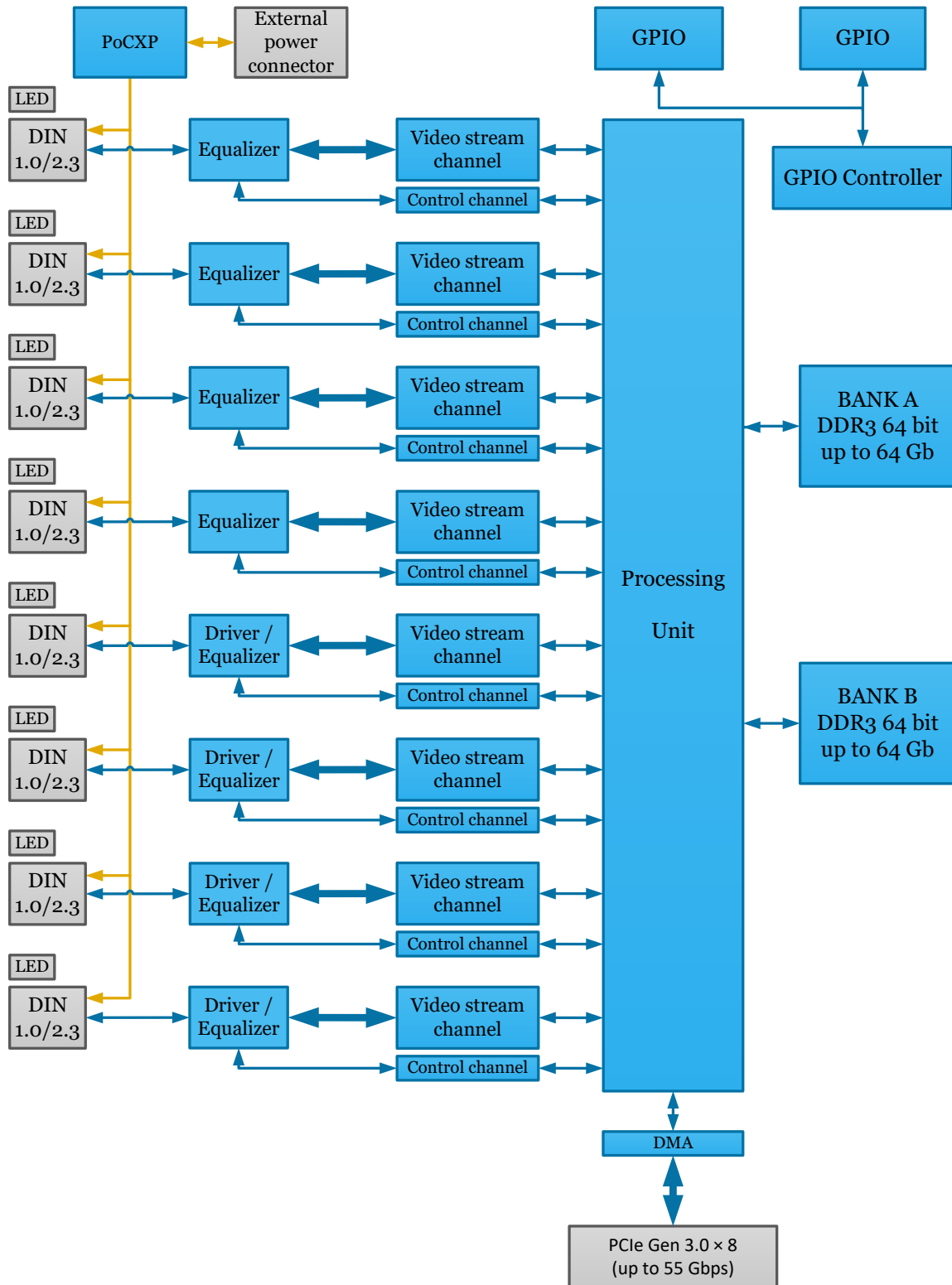

Figure 6: Komodo Board Block Diagram

6.6 Video stream acquisition

Komodo is designed to acquire different video streams compliant with CoaXPress standard 1.0 over up to 4 CoaXPress links.

When connected to transmitting device, the frame grabber communicates with Camera device to determine link parameters, such as data rate.

For different options please refer to Vision Point Application User Manual.

6.7 Auxiliary Input/Output signals

The auxiliary signal of Komodo board can be used to initiate on-board events, transmitted to other devices or rerouted from other signals, such as CoaXPress triggers and GPIO's.

Additionally, these auxiliary signals can be used to communicate with complex devices, such as encoders, strobe controls and drive controls.

The GPIOs can be controlled from the Vision Point API and be set as a trigger sources. The API enables routing of any input to any output as well as to the CXP IO and Trigger lines. Please see the API documentation for more information regarding the GPIO configuration.

The Komodo's GPIO structure consists of 2 corresponding IO headers with 2.54 mm (100th) pitch.

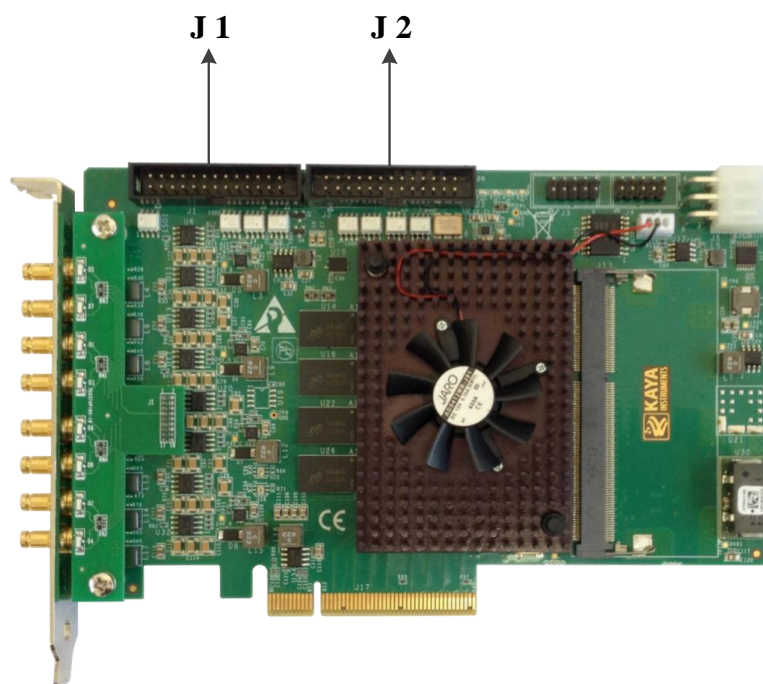

Figure 7: GPIO connectors location

The electrical connection of the GPIO connectors is described following principal schematic diagram:

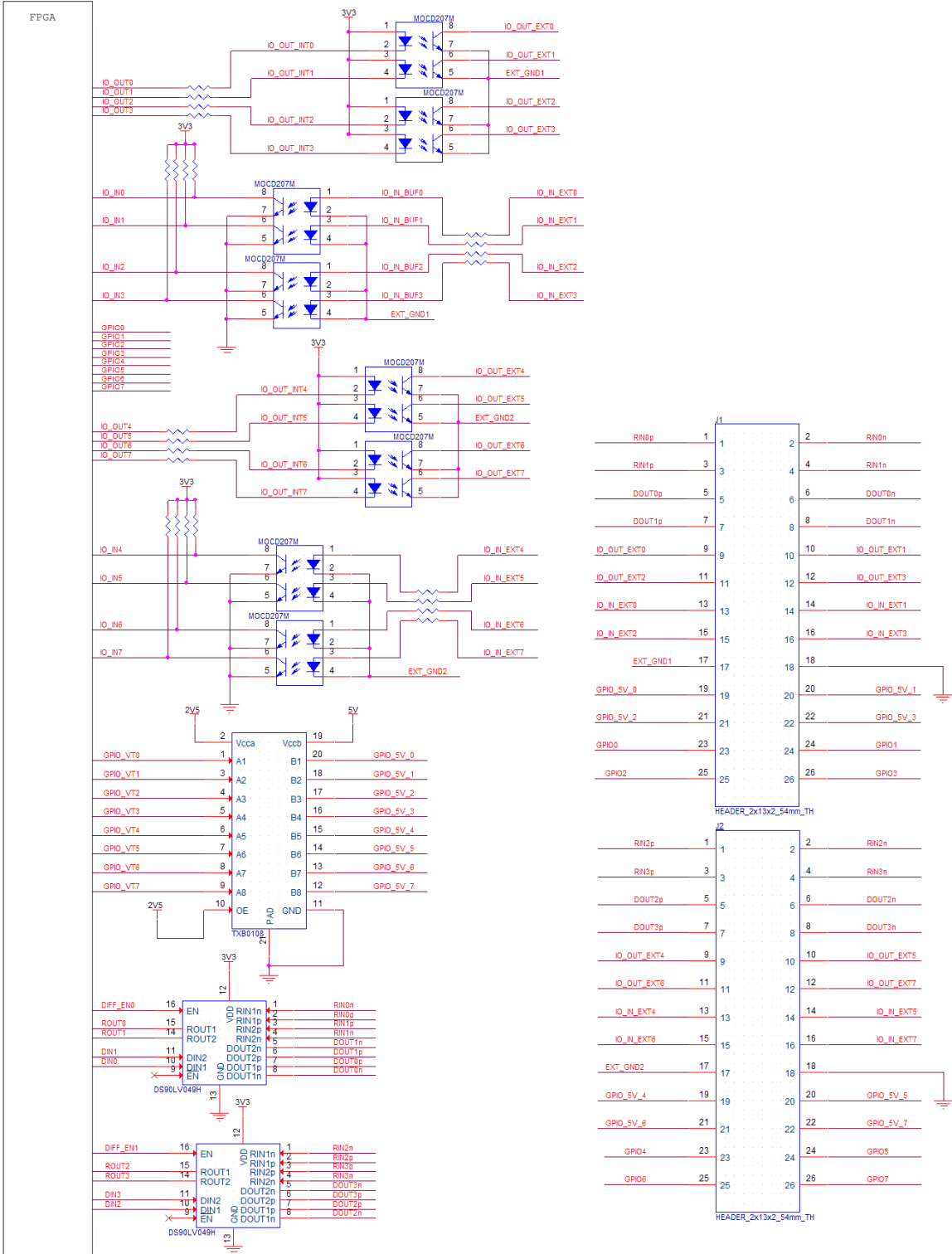

Figure 8: GPIO Connectors schematic

The pinout of each of these connectors is as described in Table 3 and Table 4.

Pin Number	Signal Name	Function	Electrical Standard	Description
1	LVDS Input 0p	LVDS input	LVDS	Positive signal of LVDS pair
2	LVDS Input 0n	LVDS input	LVDS	Negative signal of LVDS pair
3	LVDS Input 1p	LVDS input	LVDS	Negative signal of LVDS pair
4	LVDS Input 1n	LVDS input	LVDS	Negative signal of LVDS pair
5	LVDS Output 0p	LVDS output	LVDS	Positive signal of LVDS pair
6	LVDS Output 0n	LVDS output	LVDS	Positive signal of LVDS pair
7	LVDS Output 1p	LVDS output	LVDS	Negative signal of LVDS pair
8	LVDS Output 1n	LVDS output	LVDS	Negative signal of LVDS pair
9	OptoCoupled Output 0	Opto-Isolated output	Up to 70V	Optically isolated outputs
10	OptoCoupled Output 1	Opto-Isolated output	Up to 70V	Optically isolated outputs
11	OptoCoupled Output 2	Opto-Isolated output	Up to 70V	Optically isolated outputs
12	OptoCoupled Output 3	Opto-Isolated output	Up to 70V	Optically isolated outputs
13	OptoCoupled Input 0	Opto-Isolated input	Up to 70V	Optically isolated inputs
14	OptoCoupled Input 1	Opto-Isolated input	Up to 70V	Optically isolated inputs
15	OptoCoupled Input 2	Opto-Isolated input	Up to 70V	Optically isolated inputs
16	OptoCoupled Input 3	Opto-Isolated input	Up to 70V	Optically isolated inputs
17	OptoCoupled GND	External GND		Ground signal for opto-isolated signals on this connector.
18	GND	Board GND		Reference ground signal
19	TTL 0	GPIO	TTL (Open-drain)	General Purpose IO
20	TTL 1	GPIO	TTL (Open-drain)	General Purpose IO
21	TTL 2	GPIO	TTL (Open-drain)	General Purpose IO
22	TTL 3	GPIO	TTL (Open-drain)	General Purpose IO
23	LVTTL 0	GPIO	LVTTL	General Purpose IO
24	LVTTL 1	GPIO	LVTTL	General Purpose IO
25	LVTTL 2	GPIO	LVTTL	General Purpose IO
26	LVTTL 3	GPIO	LVTTL	General Purpose IO

Table 3: J1 connector pinout

Pin Number	Signal Name	Function	Electrical Standard	Description
1	LVDS Input 2p	LVDS input	LVDS	Positive signal of LVDS pair
2	LVDS Input 2n	LVDS input	LVDS	Positive signal of LVDS pair
3	LVDS Input 3p	LVDS input	LVDS	Negative signal of LVDS pair
4	LVDS Input 3n	LVDS input	LVDS	Negative signal of LVDS pair
5	LVDS Output 2p	LVDS output	LVDS	Positive signal of LVDS pair
6	LVDS Output 2n	LVDS output	LVDS	Positive signal of LVDS pair
7	LVDS Output 3p	LVDS output	LVDS	Negative signal of LVDS pair
8	LVDS Output 3n	LVDS output	LVDS	Negative signal of LVDS pair
9	OptoCoupled Output 4	Opto-Isolated output	Up to 70V	Optically isolated outputs
10	OptoCoupled Output 5	Opto-Isolated output	Up to 70V	Optically isolated outputs
11	OptoCoupled Output 6	Opto-Isolated output	Up to 70V	Optically isolated outputs
12	OptoCoupled Output 7	Opto-Isolated output	Up to 70V	Optically isolated outputs
13	OptoCoupled Input 4	Opto-Isolated input	Up to 70V	Optically isolated inputs
14	OptoCoupled Input 5	Opto-Isolated input	Up to 70V	Optically isolated inputs
15	OptoCoupled Input 6	Opto-Isolated input	Up to 70V	Optically isolated inputs
16	OptoCoupled Input 7	Opto-Isolated input	Up to 70V	Optically isolated inputs
17	OptoCoupled GND	External GND		Ground signal for opto-isolated signals on this conector
18	GND	Board GND		Reference ground signal
19	TTL 4	GPIO	TTL (Open-drain)	General Purpose IO
20	TTL 6	GPIO	TTL (Open-drain)	General Purpose IO
21	TTL 5	GPIO	TTL (Open-drain)	General Purpose IO
22	TTL 7	GPIO	TTL (Open-drain)	General Purpose IO
23	LVTTL 4	GPIO	LVTTL	General Purpose IO
24	LVTTL 5	GPIO	LVTTL	General Purpose IO
25	LVTTL 6	GPIO	LVTTL	General Purpose IO
26	LVTTL 7	GPIO	LVTTL	General Purpose IO

Table 4: J2 connector pinout

6.8 Absolute maximum ratings

Specification	Values
3.3V power supply	-1.0V to +7.0V
12V power supply	-0.3V to 14V
Storage temperature	-55°C to 125°C
Operating ambient temperature	0°C to 50°C

Table 5: Absolute maximum ratings

Specification	Minimum voltage [V]	Maximum voltage [V]
LVDS	-0.3	3.6
Opto-isolated (in)	-6	60
Opto-isolated (out)	-7	70
TTL	-0.5	6
LVTTL	-0.5	3.9

Note: The maximum current that the Opto-isolated (out) IOs can support is 150mA

Table 6: Absolute maximum ratings for GPIO

6.9 Electrical characteristics for board IO's:

Electrical characteristics for board IO's:

Symbol	Parameter	Condition	Pin	MIN	Typ	MAX	Units
$ V_{OD} $	Differential Output Voltage	$R_L = 100 \Omega$	D_{OUT-} D_{OUT+}	250	350	450	mV
ΔV_{OD}	Change in Magnitude of V_{OD} for Complementary Output States				1	35	mV
V_{OS}	Offset Voltage			1.125	1.23	1.375	V
ΔV_{OS}	Change in Magnitude of V_{OS} for Complementary Output States				1	25	mV

I_{OS}	Output Short Circuit Current ⁽⁴⁾	ENABLED, $D_{IN} = V_{DD}$, $D_{OUT+} = 0\text{ V}$ or $D_{IN} = GND$, $D_{OUT-} = 0\text{ V}$			-5.8	-9.0	mA
I_{OSD}	Differential Output Short Circuit Current ⁽⁴⁾	ENABLED, $V_{OD} = 0\text{ V}$			-5.8	-9.0	mA
I_{OFF}	Power-off Leakage	$V_{OUT} = 0\text{ V}$ or 3.6 V $V_{DD} = 0\text{ V}$ or Open		-20	± 1	+20	μA
I_{OZ}	Output TRI-STATE Current	$EN = 0\text{ V}$ and $EN = V_{DD}$ $V_{OUT} = 0\text{ V}$ or V_{DD}		-10	± 1	+10	μA

Table 7: LVDS Output DC specifications (Driver Outputs)

Symbol	Parameter	Condition	Pin	MIN	Typ	MAX	Units
V_{TH}	Differential Input High Threshold	$V_{CM} = 1.2\text{ V}$, 0.05 V , 2.35 V	R_{IN+} R_{IN-}		-15	35	mV
V_{TL}	Differential Input Low Threshold			-100	-15		mV
V_{CMR}	Common-Mode Voltage Range	$V_{ID} = 100\text{ mV}$, $V_{DD} = 3.3\text{ V}$		0.05		3	V
I_{IN}	Input Current	$V_{DD} = 3.6\text{ V}$ $V_{IN} = 0\text{ V}$ or 2.8 V		-12	± 4	+12	μA
		$V_{DD} = 0\text{ V}$ $V_{IN} = 0\text{ V}$ or 2.8 V or 3.6 V	-10	± 1	+10	μA	

Table 8: LVDS Input DC specifications (Receiver Inputs)

Symbol	Parameter	Test condition (note 1)	MIN	MAX	Units
V_{IH}	Input High Voltage	$V_{OUT} \geq V_{OH(min)}$ or $V_{OUT} \leq V_{OL(max)}$	2	$V_{DD}+0.3$	V
V_{IL}	Input Low Voltage		-0.3	0.8	V
I_{IN}	Input Current	$V_{IN} = 0\text{ V}$ or $V_{IN} = V_{DD}$		± 5	μA

Note: Vdd = 3.3V, unless specified otherwise

Table 9: LVTTL input specifications

Symbol	Parameter	Test condition	MIN	MAX	Units
V_{OH}	Output High Voltage	$V_{DD} = \text{min}$, $I_{OH} = -2\text{ mA}$	2.4		V
V_{OL}	Output Low Voltage	$V_{DD} = \text{min}$, $I_{OL} = 2\text{ mA}$		0.4	V

Note: Vdd = 3.3V, unless specified otherwise

Table 10: LVTTL output specifications

Symbol	Parameter	Test condition (note 1)	MIN	MAX	Units
V_{IH}	Input High Voltage	$V_{OUT} \geq V_{OH(min)}$ or $V_{OUT} \leq V_{OL(max)}$	2	5	V
V_{IL}	Input Low Voltage		-0.3	0.8	V
I_{IN}	Input Current	$V_{IN} = 0\text{ V}$ or $V_{IN} = V_{DD}$		± 5	μA

Note: $V_{dd} = 5\text{V}$, unless specified otherwise

Table 11: TTL input specifications

Symbol	Parameter	Test condition	MIN	MAX	Units
V_{OH}	Output High Voltage	$V_{DD} = \text{min}$, $I_{OH} = -2\text{ mA}$	4		V
V_{OL}	Output Low Voltage	$V_{DD} = \text{min}$, $I_{OL} = 2\text{ mA}$		0.4	V

Note: $V_{dd} = 5\text{V}$, unless specified otherwise

Table 12: TTL output specifications

International Distributors



Sky Blue Microsystems GmbH
 Geisenhausenerstr. 18
 81379 Munich, Germany
 +49 89 780 2970, info@skyblue.de
 www.skyblue.de



In Great Britain:
 Zerif Technologies Ltd.
 Winnington House, 2 Woodberry Grove
 Finchley, London N12 0DR
 +44 115 855 7883, info@zerif.co.uk
 www.zerif.co.uk