



CoaXPress™ Range Extender over Coax

User Manual 2015

International Distributors



Sky Blue Microsystems GmbH
Geisenhausenerstr. 18
81379 Munich, Germany
+49 89 780 2970, info@skyblue.de
www.skyblue.de



In Great Britain:
Zerif Technologies Ltd.
Winnington House, 2 Woodberry Grove
Finchley, London N12 0DR
+44 115 855 7883, info@zerif.co.uk
www.zerif.co.uk

1	Figures and Tables.....	2
2	Introduction	3
2.1	Safety Precautions.....	3
2.2	Disclaimer	4
3	Key Features.....	6
3.1	Overview	6
3.2	Features	6
3.3	Product Applications.....	6
3.4	Related documents and accessories	7
4	System Description.....	8
4.1	External View of the KY-EXT6G	8
4.2	Power supply.....	8
5	Installation and Connectivity.....	10
5.1	Installation procedure.....	10
6	Firmware.....	12
6.1	Terminal control.....	12
6.2	Firmware update	13
7	Electrical Specifications	14
7.1	Absolute maximum ratings	14
7.2	Operating conditions	14
8	Mechanical Specifications.....	15
8.1	Dimensions.....	15
9	Appendices	16
9.1	CoaXPress cables	16
10	Ordering information	17
10.1	Ordering information	17

Figures

FIGURE 1 : *KY-EXT6G* HOST EXTERNAL VIEW 8

FIGURE 2 : *KY-EXT6G* DEVICE EXTERNAL VIEW..... 8

FIGURE 3 : *KY-EXT6G* POWER CONNECTOR 9

FIGURE 4 : *KY-EXT6G* HOST SIDE LEDs 9

FIGURE 5 : *KY-EXT6G* DEVICE SIDE LEDs 9

FIGURE 6 : *KY-EXT6G* CONNECTION DIAGRAM..... 10

FIGURE 7 : EXTERNAL DIMENSIONS OF THE *KY-EXT6G* ENCLOSURE BOX 15

Tables

TABLE 1 : CXP STATUS LEDs BEHAVIOR 9

TABLE 2 : SERIAL EMULATED TERMINAL CONFIGURATIONS 12

TABLE 3 : TERMINAL COMMANDS 12

TABLE 4 : ABSOLUTE MAXIMUM RATINGS..... 14

TABLE 5 : OPERATING CONDITIONS..... 14

TABLE 6 : ORDERING INFORMATION 17

Revision History

Version	Date	Notes
1.0	10.06.15	Initial Release
1.1	26.07.15	Minor image changes

2.1 Safety Precautions

With your CoaXPress™ Range Extender over Fiber (KY-EXT6G) in hand, please take a minute to read carefully the precautions listed below in order to prevent unnecessary injuries to you or other personnel or cause damage to property.

- **Before using the product, read these safety precautions carefully to assure correct use.**
- **These precautions contain serious safety instructions that must be observed.**
- **After reading through this manual, be sure to act upon it to prevent misuse of product.**



Caution

<p>In the event of a failure, disconnect the power supply. If the product is used as is, a fire or electric shock may occur. Disconnect the power supply immediately and contact our sales personnel for repair.</p>
<p>If an unpleasant smell or smoking occurs, disconnect the power supply. If the product is used as is, a fire or electric shock may occur. Disconnect the power supply immediately. After verifying that no smoking is observed, contact our sales personnel for repair.</p>
<p>Do not disassemble, repair or modify the product. Otherwise, a fire or electric shock may occur due to a short circuit or heat generation. For inspection, modification or repair, contact our sales personnel.</p>
<p>Do not touch a cooling fan. As a cooling fan rotates in high speed, do not put your hand close to it. Otherwise, it may cause injury to persons. Never touch a rotating cooling fan.</p>
<p>Do not place the product on unstable locations. Otherwise, it may drop or fall, resulting in injury to persons or failure.</p>
<p>If the product is dropped or damaged, do not use it as is. Otherwise, a fire or electric shock may occur.</p>
<p>Do not touch the product with a metallic object. Otherwise, a fire or electric shock may occur.</p>
<p>Do not place the product in dusty or humid locations or where water may splash. Otherwise, a fire or electric shock may occur.</p>
<p>Do not get the product wet or touch it with a wet hand. Otherwise, the product may break down or it may cause a fire, smoking or electric shock.</p>
<p>Do not touch a connector on the product (gold-plated portion). Otherwise, the surface of a connector may be contaminated with sweat or skin oil, resulting in contact failure of a connector or it may cause a malfunction, fire or electric shock due to static</p>

electricity.
Do not use or place the product in the following locations. <ul style="list-style-type: none">● Humid and dusty locations● Airless locations such as closet or bookshelf● Locations which receive oily smoke or steam● Locations close to heating equipment● Closed inside of a car where the temperature becomes high● Static electricity replete locations● Locations close to water or chemicals Otherwise, a fire, electric shock, accident or deformation may occur due to a short circuit or heat generation.
Do not place heavy things on the product. Otherwise, the product may be damaged.
Do not look into the fiber optic cable or the panel mounted SFP connectors. In order to avoid possible exposure to (Class 1) laser energy.

2.2 Disclaimer

This product should be used for increasing the CoaXPress video transmission distance. It also can be used for transmitting CoaXPress video over fiber in environments where standard coaxial cable is not applicable. KAYA Instruments assumes no responsibility for any damages resulting from the use of this product for purposes other than those stated.

Even if the product is used properly, KAYA Instruments assumes no responsibility for any damages caused by the following:

- Earthquake, thunder, natural disaster or fire resulting from the use beyond our responsibility, acts caused by a third party or other accidents, the customer's willful or accidental misuse or use under other abnormal conditions.
- Secondary impact arising from use of this product or its unusable state (business interruption or others).
- Use of this product against the instructions given in this manual or malfunctions due to connection to other devices.

KAYA Instruments assumes no responsibility or liability for:

- Erasure or corruption of data arising from use of this product.
- Any consequences or other abnormalities arising from use of this product, or damage of this product not due to our responsibility or failure due to modification.

This product is covered with one year limited warranty. The customer is responsible for all shipping charges to return the faulty device to KAYA Instruments and back.

Repair of this product, out of warranty period, is carried out by replacing it on a chargeable basis, not repairing the faulty devices.

3.1 Overview

KAYA Instruments' *CoaXPress Range Extender over Coax (KY-EXT6G)* provides a high resolution CoaxPReSSs interface extension over distances of up to 300m over standard coaxial cable. A single extender box extends the connection length to twice the length, while two chained extender triples the connection length. Up to 3 chained extender are supported. The extender can either receive his power from CoaXPress link, or from external power adapter. When an external power adaptor is used, it also injects power to the camera side links, therefore frame grabbers without PoCXP support can be used.

3.2 Features

- Extends of up to 4 CoaXPress channels
- Both ends of CXP_6 is supported with up to 6.25 Gbps downlink, 20.83 Mbps uplink
- Extension for distances up to 300m with up to 3 chained extenders.
- Bidirectional CoaXPress communication
- DIN Connector s for CoaXPress link
- Plug and Play , no need to configure
- Power over CoaXPress (PoCXP) support
- 0°C to 50°C operating environment temperature

3.3 Product Applications

- ✓ High speed cameras
- ✓ High definition cameras
- ✓ Panoramic cameras
- ✓ Defense remote systems
- ✓ Surveillance
- ✓ Robotic Vision

3.4 Related documents and accessories

Documents:

- Japan Industrial Imaging Association (JIIA NIF-001-2010)

Optional accessories:

- 24V 65 W power supply

4.1 External View of the KY-EXT6G

Each *KY-EXT6G* unit is housed in a compact, metal enclosure. Each unit has a power connector, 4 coax connectors from each side and a Mini USB Terminal interface, as shown in Figure 1 and Figure 2

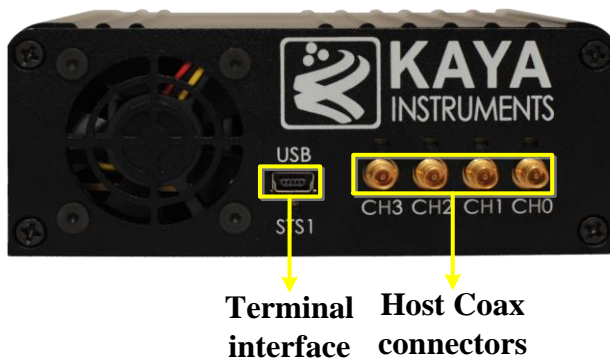

Figure 1 : KY-EXT6G host external view

Figure 2 : KY-EXT6G device external view

Each of the coax connector is paired with a status LED and there is a system status LED (see Table 1 describing the LED status).

Each unit also has mount ears for an easy and secure installation on any flat surface.

4.2 Power supply

The extender is compatible with PoCXP standard and therefore doesn't require external power supply, once the Frame Grabber supports this feature too. If the frame grabber is unable to supply the power or there are high power losses on the cable an optional external power supply of 24V can be added.

Connect the positive wire from the power supply to the "+" connector, connect the GND pin of connector to the ground wire and the negative wire to the "-" connector, as seen in Figure 3.

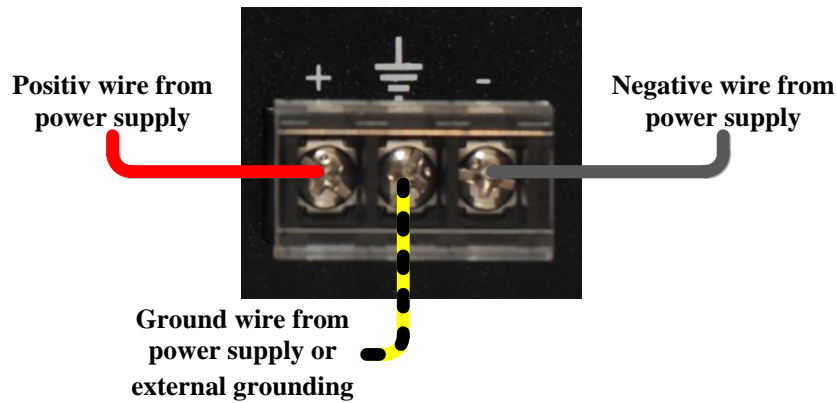

Figure 3 : KY-EXT6G power connector

Each unit has several status LEDs, as seen in Figure 4 and Figure 5.

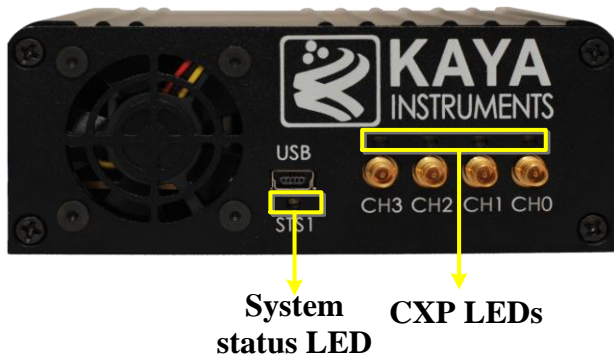

Figure 4 : KY-EXT6G host side LEDs



Figure 5 : KY-EXT6G device side LEDs

The System status LED, located on the coax side, always slow pulses in green while the system is ON. While in firmware update mode, this LED slow pulses orange. In any case of system failure, the LED will constantly light orange.

The CXP LED's behavior is described in Table 1:

LED state	Condition
Slow pulse red	No valid CoaXPress low speed link detected
Solid red	PoCXP failure (Overcurrent/Under voltage/Overvoltage)
Fast flash green	CoaXPress link speed is being negotiated
Solid green	CoaXPress link is active

Table 1 : CXP status LEDs behavior

5.1 Installation procedure

The *KY-EXT6G* extender uses a single unit to extend a CXP range twice. A multiple units can be chained to extend the range even further. The device side of the extender must be connected to the camera, while the host side to the frame grabber, as described in Figure 6:

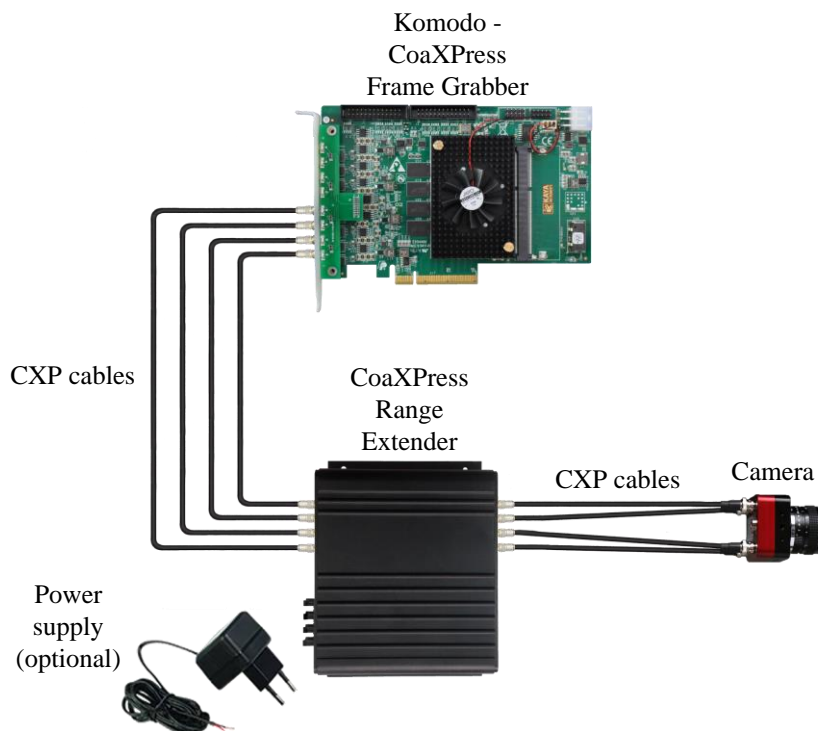

Figure 6 : *KY-EXT6G* connection diagram

In order to properly use the *KY-EXT6G* extender, the following steps must be taken for initial power up:

1. If required, connect the optional Power Adaptors to the *KY-EXT6G* units.
2. Connect the camera to the *KY-EXT6G* adaptor from the camera side.
3. Connect the frame grabber to the *KY-EXT6G* from the frame grabber side.
4. Turn the camera and the frame grabber on and start your application software.

NOTES:

1. If using PoCXP link 0 must be always connected as it is used to power the extender
2. The same link must be used from both sides of the extender box. For example, if camera is connected to link 0 on the camera side, frame grabber must be connected to link 0 on the frame grabber side.

6.1 Terminal control

A Mini USB port is available for individual link & general information status and firmware update. The port uses a Silabs CP2101 chip. A driver from the Silabs website might have to be installed on certain PCs to gain access to the terminal port. Free supporting driver can be found at: <http://www.silabs.com/products/mcu/pages/usbtouartbridgevcpdrivers.aspx>

After driver installation and USB connection is acquired a serial emulated terminal (i.e. Tera Term use is recommended) can be used with the following configurations, described in Table 2:

Parameter	Value
Baud rate	115200
Start bits	1
Stop bits	1
Parity	None
Flow Control	None

Table 2 : Serial emulated terminal configurations

The following commands are supported by the terminal; each command must be followed by carriage return (Enter) in order to execute:

Command	Description
firmware	Sets the system to firmware update mode. See 6.2 chapter for firmware update information
status	Prints the system and individual link status and general information

Table 3 : Terminal commands

NOTE: The commands are not case sensitive.

6.2 Firmware update

1. The extender supports firmware update via USB using a serial emulated terminal. To initiate firmware update the following steps should be taken:
2. Connect the USB cable to the extender and acquire connection using Silabs drivers (drivers need to be downloaded manually if an automatic download isn't initiated).
3. Open serial emulated terminal (usage of Tera Term terminal is recommended) and set serial communication protocol as described in Section 6.1.
4. In the terminal window type "status" followed by carriage return and checks the current firmware version.
5. Choose the firmware update option by entering "firmware" followed by carriage return and wait for the following message: "Now starting firmware update, please start file transfer using XMODEM:"
6. At this point all the LEDs will turn off and the "System status LED" will slow pulse orange indicating the extender is ready to receive the firmware binary file. Under "File" tab use the terminal "transfer" capability using the XMODEM protocol to initiate the firmware update. Choose "Send" and the firmware version: CXP_EXT_x_xx.rbf, when x_xx is the version number.
7. If no firmware will be sent during 1 minute, or in case of an error the firmware update will fail and return to previous operation mode.
8. A successful update will result in appropriate message and a reboot of the extender to new firmware.
9. Check the firmware version by typing "status" followed by carriage return. Make sure that the firmware version matches the version on the firmware update package supplied; that would insure the success of the firmware update operation.

7.1 Absolute maximum ratings

Specification	Values
Power supply voltage	0V to 30V
Storage Temperature	-40°C to 85°C
Operating Temperature	0°C to 50°C

Table 4 : Absolute maximum ratings

7.2 Operating conditions

Parameter	Description	Minimum	Typical	Maximum
V _{cc}	Supply voltage	20.3V	24V	26 V
I _{cc} (Host)	Supply Current from PoCXP or external power supply (4 active channels)	-	0.25A	0.33A
I _{cc} (Device)	Supply Current from external power supply (4 active channels)	-	0.25A	2.61A ⁽¹⁾
I _{PoCXP}	PoCXP Output current per link	0A	-	0.57A

Table 5 : Operating conditions

(1) In case all the 4 CXP channels supply 13.5W of power to connected camera

8.1 Dimensions

Each *KY-EXT6G* unit is housed in a metal enclosure as shown in Figure 7:

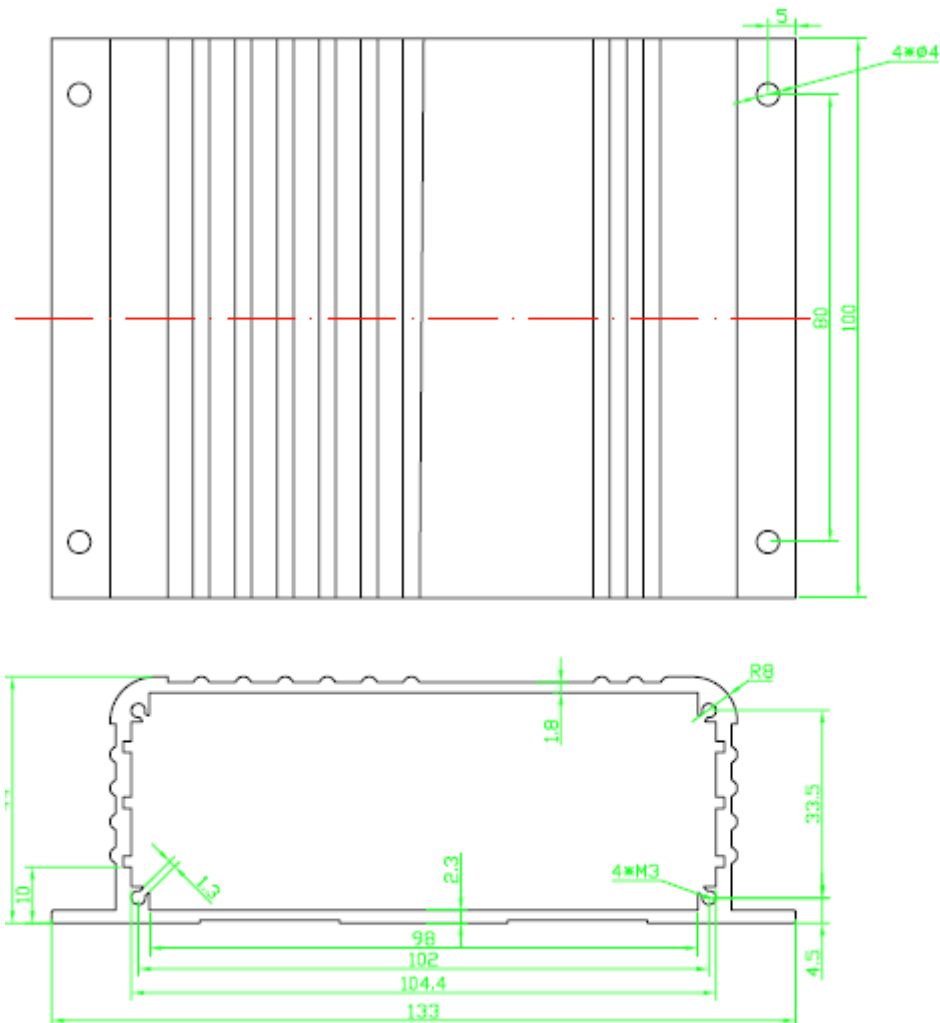

Figure 7 : External dimensions of the KY-EXT6G enclosure box

9.1 CoaXPress cables

CoaXPress is a new digital transmission standard that allows high speed data from a device, such as a camera, to be transferred to a host, such as a frame grabber. Each CoaXPress link supports up to 6.25 Gbps data rates, along with device power up to 13W and device control at 20 Mbps – all on a single coax cable. For very fast devices, the links can be aggregated to provide multiples of the single coax bandwidth. Long cable lengths are supported – up to 40 meters at 6.25 Gbps and over 100 meters at 3.125 Gbps.



10.1 Ordering information

Item name	Item part number
CoaXPress Range Extender over Coax (4 channel)	KY-EXT6G
Power supply 24V , 65W	KY_PWR_65

Table 6 : Ordering Information

International Distributors

 sky blue
microsystems

Sky Blue Microsystems GmbH
Geisenhausenerstr. 18
81379 Munich, Germany
+49 89 780 2970, info@skyblue.de
www.skyblue.de

 **ZERIF**
TECHNOLOGIES LTD.
A SKY BLUE COMPANY, FOUNDED 1999

In Great Britain:
Zerif Technologies Ltd.
Winnington House, 2 Woodberry Grove
Finchley, London N12 0DR
+44 115 855 7883, info@zerif.co.uk
www.zerif.co.uk