

# 385A-SoC

System-on-Chip FPGA Accelerator Card

The 385A-SoC™ low profile accelerator card provides a powerful computing and I/O platform for FPGA and ARM-based development and deployment across a range of application areas including High Performance Computing, Image Processing and Network Analytics.

The 385A-SoC is an 8-lane PCIe Gen 3 card featuring an Altera Arria 10 SoC FPGA and DDR4 SDRAM external memory.

Two QSFP network ports enable support for a range of high speed serial I/O protocols (40GbE, 10GbE, 1GbE, Common Public Radio Interface and Fiber Channel) with speeds up to 40Gbps.

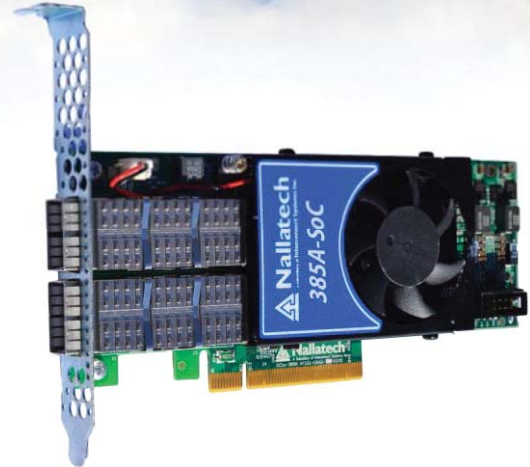

## ARM-Based FPGA/SoC Delivers Optimal Performance at Low Cost for Real-Time Applications

### Application Use Cases

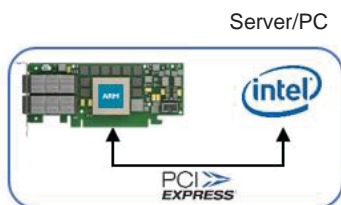

#### » PCIe-attached

- Use the 385A-SoC integrated in a server/PC
- FPGA/SoC is tightly coupled to the host processor via PCIe
- Off-load compute and I/O functions to the FPGA and ARM processors

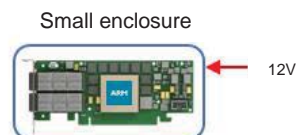

#### » Stand-alone

- Use the 385A-SoC as a stand-alone instrument, unattached to a PCIe Host
- Card is mechanically hosted in a small enclosure
- Power is applied to the enclosure via the 12V AUX connector
- OS (including RTOS) executes on an embedded ARM processor
- Up to 1TB of mass storage using two solid state disks (SSD)

The Leader in FPGA  
Accelerated Computing

 **Nallatech**  
a **molex** company

## Specification Highlights

### Form factor

- » Low profile, single width PCI Express card
- » Half height, half length
- » 2.713 x 6.6 inches

### Processing

- » Altera Arria 10 SX F34 package
- » Default configuration: SX 660, speed grade 2

### DDR4 SDRAM memory (FPGA)

- » One bank of DDR4 SDRAM x 72 for FPGA fabric
- » 4GB @ 2133 MT/s

### DDR4 SDRAM memory (ARM processors)

- » One bank of DDR4 SDRAM x 40 for ARM processors
- » 2GB @ 2133 MT/s

### Host interface

- » 8-lane PCI-Express Gen 3
- » Actual performance is host computer chipset and operating system dependant

### Application Development

- » Supports multiple design flows including HDL
- » On-card power derived from 12V PCIe slot or AUX connector (when used in stand-alone mode)

- » FPGA power dissipation is application dependent

### Quality

- » Manufactured to ISO9001:2000 IPC-A-610-Class III
- » ROHS compliant

### Power Supply Monitoring & Reporting

- » On-board Altera USB Blaster
- » Voltage monitoring
- » Temperature monitoring
- » Fault condition reporting to FPGA

### High Speed Serial IO interfaces

- » Two QSFP supporting datarates up to 40 Gbps
- » Default clocking support: 40GbE, 10GbE, 1GbE, CPRI and Fiber Channel

## Functional Diagram

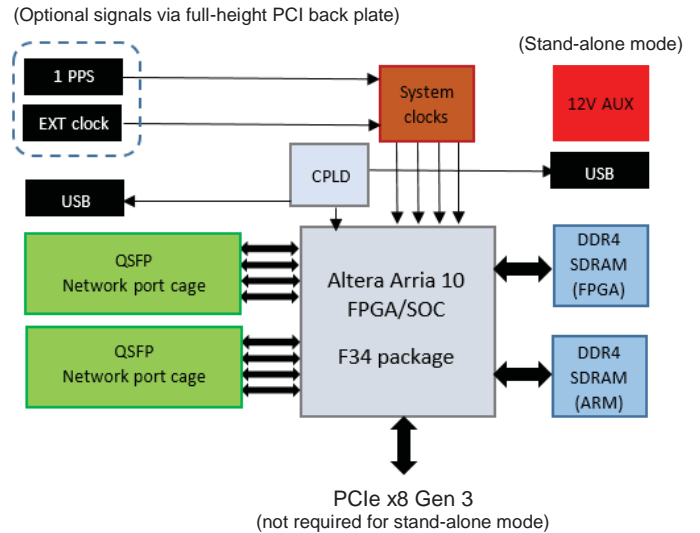

### Cooling

- » Standard: single-width active heatsink (embedded fan)
- » Optional: Passive heatsink

### Environmental

- » Cooling: Air convection
- » Operating temperature: 0°C to 35°C
- » Storage temperature: -20°C to 80°C
- » Relative humidity: 45 to 95% (non-condensing)

### Deliverables

- » 385A-SoC FPGA card
- » Built-In-Self-Test (BIST)
- » Full and half-height PCI back plates available
- » 1 year access to online support lounge
- » 1 year hardware warranty

### International Distributors



Sky Blue Microsystems GmbH  
Geisenhausenerstr. 18  
81379 Munich, Germany  
+49 89 780 2970, info@skyblue.de  
www.skyblue.de



In Great Britain:  
Zerif Technologies Ltd.  
Winnington House, 2 Woodberry Grove  
Finchley, London N12 0DR  
+44 115 855 7883, info@zerif.co.uk  
www.zerif.co.uk



Nallatech accelerator cards are available pre-integrated in server platforms from leading vendors. Nallatech also offers application porting and optimization services. Please visit [www.nallatech.com](http://www.nallatech.com)