

A5PL (A5-PCIe-L)

Intel Arria® V GZ Low Profile PCIe Board with Dual QSFP+ and DDR3, QDRII+, or RLDRAM3

- High performance Intel Arria V GZ FPGA
- PCIe x8 interface supporting Gen1, Gen2, or Gen3
- Dual QSFP+ cages for 2x 40GigE or 8x 10GigE
- Memory options:
 - up to 8 GBytes of DDR3 SDRAM with ECC
 - up to 512 MBytes RLDRAM3
 - up to 72 MBytes QDRII+
- Board Management Controller for Intelligent Platform Management
- USB 2.0 for programming and debug
- Timestamping and synchronization support



BittWare's A5-PCIe-L (A5PL) is a low-profile PCIe x8 card based on the Intel Arria V GZ FPGA. The high-performance, power- and cost-efficient Arria V GZ provides a high level of system integration and flexibility for I/O, routing, and processing. Up to 8 GBytes of on-board memory includes DDR3, QDRII/II+, or RLDRAM3. Two front-panel QSFP+ cages allow two 40GigE or eight 10GigE interfaces. The A5PL also features a Board Management Controller (BMC) for advanced system monitoring, which greatly simplifies platform management. All of these features combine to make the A5PL a versatile and efficient solution for network processing, security, broadcast, and signals intelligence applications.

Intel Arria V GZ FPGA

The 28nm Arria V family of FPGAs deliver optimal performance, power, and cost efficiency for mid-range applications. The Arria V GZ variant, which is featured on the A5PL, offers the highest bandwidth of the Arria V FPGAs. The Arria V GZ provides Gen3 PCIe x8 via a hard IP block and features 16 full-duplex transceivers with data rates up to 12.5 Gbps, and up to 450K equivalent LEs.

I/O Interfaces

The A5PL provides a variety of interfaces for high-speed serial I/O as well as debug support. Two QSFP+ cages are available on the front panel, each supporting 40GigE or four 10GigE channels using optical transceivers as well as passive copper cabling up to 8 meters. The QSFP+ cages can optionally be adapted for SFP+.

The Gen3 x8 PCIe interface provides 8 SerDes lanes to the Arria V GZ FPGA. A USB 2.0 interface and an optional JTAG connector are available for debug and programming support.

Timestamping and Synchronization

The board supports timestamping and synchronization with optional SMA connectors on the front panel for a 1 PPS and reference clock input.* A tunable, high accuracy, temperature compensated oscillator (TCXO) and a programmable clock synthesizer (Si5338) provide sophisticated timing and clocking options. IP is also available for IEEE 1588 Precision Time Protocol (PTP).

Memory

The A5PL features an extremely flexible memory configuration, with a SODIMM site that supports DDR3 SDRAM, RLDRAM3, and QDRII+. Memory card options include the following: up to 8 GBytes of DDR3 with optional error-correcting codes (ECC); up to 72 MBytes QDRII+ (2 banks x18); or up to 512 MBytes RLDRAM3 (2 banks x18). Additional on-board memory includes flash memory for storing multiple FPGA images. An on-board PROM provides access to the board's MAC ID.

* Requires full-height front panel

A5-PCIe-L

Board Management Controller

Boards in BittWare's A5 family feature an advanced system monitoring subsystem, similar to those typically found on today's server platforms. At the heart of the board's monitoring system lies a Board Management Controller (BMC), which accepts Intelligent Platform Management Interface (IPMI) messaging protocol commands. The BMC provides a wealth of features, including control of power and resets, monitoring of board sensors, FPGA boot loader, voltage overrides, configuration of programmable clocks, access to I²C bus components, field upgrades, and IPMI messaging. Access to the BMC is via PCIe or USB. BittWare's BittWorks II Toolkit also provides utilities and libraries for communicating with the BMC components at a higher, more abstract level, allowing developers to remotely monitor the health of the board.

Development Tools

BittWorks II Toolkit

BittWare offers complete software support for the A5PL with its BittWorks II software tools. Designed to make developing and debugging applications for BittWare's boards easy and efficient, the Toolkit is a collection of libraries and applications that provides the glue between the host application and the hardware. A variety of features allow developers to take full advantage of the Arria V GZ FPGA capabilities on the BittWare board, including FPGA control via PCIe, Flash programming, custom ISR scripts, and convenient control of FPGA loads. The Toolkit supports 32-bit, and 64-bit Windows and Linux platforms and can connect to the board via PCIe or USB, providing a common API no matter the connection method.

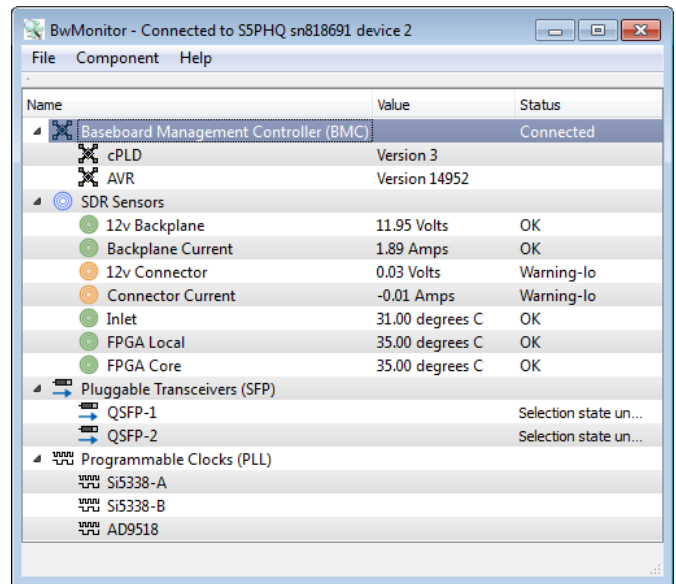

BwMonitor in the BittWorks II Toolkit provides a view into the baseboard management capabilities of your BittWare hardware.

BittWare Firmware and Network Solutions Partners

BittWare offers firmware for the Arria V GZ FPGA on the A5 family PCIe boards, targeted specifically for networking applications. BittWare's FPGA framework provides a solid base for your application, including the following:

- 10GigE MAC
- PCIe multi-channel DMA engines
- DDR3 SDRAM and QDRII/II+ controllers

BittWare has also partnered with several companies to offer solutions for financial acceleration:

- **Algo-Logic:** Market feed handler and low latency gateway libraries
- **Argon Design:** Design services specializing in multimedia and FPGA-based high performance trading
- **Enyx:** UOE, TOE, book building IP, order management IP, Market Feed Handler
- **Fraunhofer HHI:** 10 GigE TCP & UDP Offload engines, 10GigE MACS and custom services
- **InDeLabs:** Market Data Feed Handler and custom services
- **Intilop:** Ultra low latency TOE, UOE, and MAC
- **LeWiz:** Ultra low latency, multi-session TOE IP cores
- **Network Allies:** IBM and Intel server computing systems
- **PLDA:** Low latency TCP/IP offload engine, UDP and PCIe IP cores
- **PolyBus:** Infiniband link layer and transport layer
- **Tamba Networks:** Ultra low latency Ethernet and Interlaken cores

A5-PCIe-L

A5-PCIe-L

Specifications

BOARD SPECIFICATIONS

FPGA

- Intel® Arria® V GZ FPGA
- Up to 16 full-duplex, high-performance, multi-gigabit SerDes transceivers @ up to 12.5 GHz
- Up to 450K logic elements available
- Up to 34 Mb of embedded memory
- 1.6 Gbps LVDS performance
- Up to 2278 18x18 multipliers

On-Board Memory

- Flash memory for booting FPGA

Optional SODIMM

- DDR3: x72 w/ECC
 - Up to 8 GB
- RLLDRAM3: 2x banks of x18
 - 2x (32 M x 18): 128 MB
 - 2x (64 M x 18): 256 MB
 - 2x (128 M x 18): 512 MB
- QDRII+: 2x banks of x18
 - 2x (8 M x 18): 36 MB

PCIe Interface

- x8 Gen1, Gen2, Gen3 direct to FPGA

USB Header

- USB 2.0 interface for debug and programming FPGA and Flash

Timestamp and Synchronization (Optional)

- 2 front panel SMA connectors*
 - 1 PPS input
 - Reference clock input
- Tunable high-accuracy TCXO
- Programmable clock synthesizer (Si5338)

QSFP+ Cages

- 2 QSFP+ cages on front panel connected to FPGA via 8 SerDes
- Each supports 40GigE or 4 10GigE
- Can be optionally adapted for use as SFP+

Baseboard Management Controller

- Voltage, current, temperature monitoring
- Power sequencing and reset
- Field upgrades
- FPGA configuration and control
- Clock configuration
- I²C bus access
- USB 2.0 access
- Voltage overrides

Size

- Half-height, half-length (low profile) PCIe slot card
- 168mm x 68.9mm
- Max. component height: 14.47mm

DEVELOPMENT TOOLS

System Development

- BittWorks II Toolkit - host, command, and debug tools for BittWare hardware; source code porting kit also available

FPGA Development

- Intel Tools
 - Quartus II software

* Requires full-height front panel

Figure 2: A5PL System Block Diagram

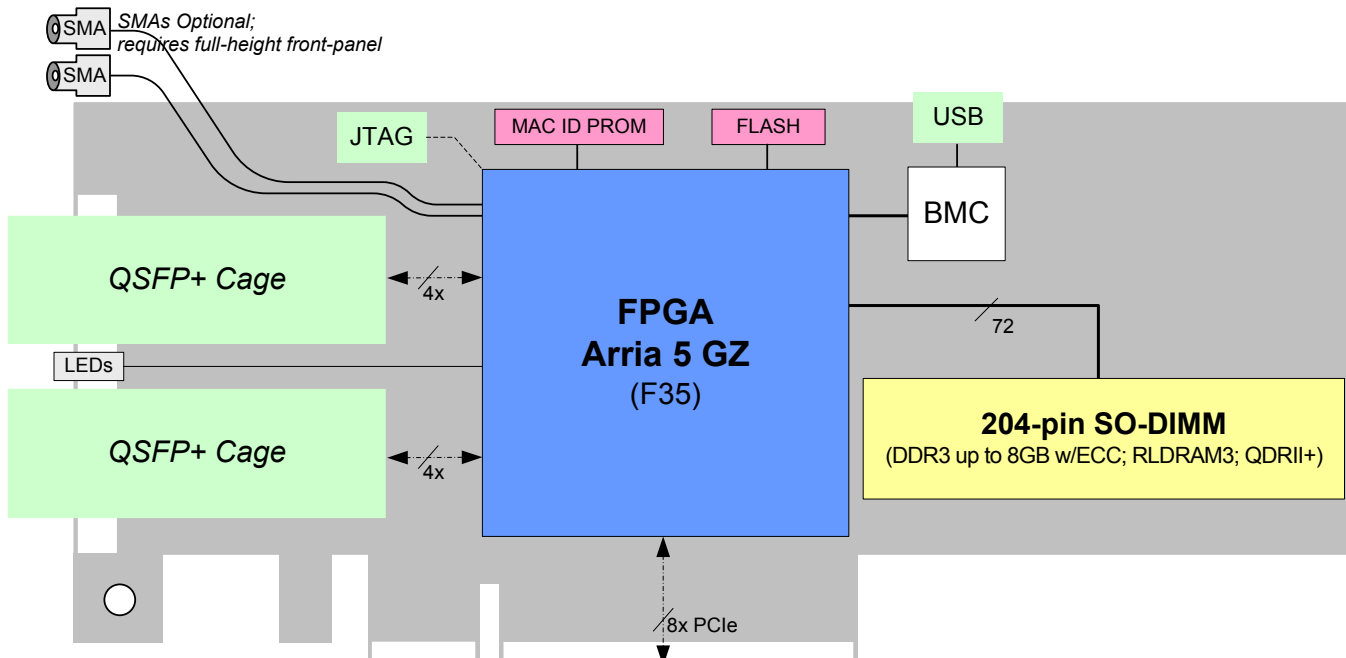

A5PL Ordering Options

A5PL-RW-AAAAAAAA-BB-CDE-FG			
RW	Ruggedization 0U = Commercial (0C to 50C)*	C	Oscillator N = None T = TCXO* A = Adjustable TCXO
AAAAAAAA	Arria V Family, HardIP, and Size GZME12C3 - Arria V GZME12C3* GZME32C3 - Arria V GZME32C3 † GZME52C3 - Arria V GZME52C3 † GZME72C3 - Arria V GZME72C3	D	Timing 0 = Not installed X = On-board circuits only* S = Front panel SMA connectors
BB	SODIMM 00 = None 99 = No socket † D3 = DDR3 8GB x72* Q2 = QDRII+ 36MB 2x18 R3 = RLDGRAM3 512MB 2x18 †	E	Misc. Configuration 1 = Default
		F	Environmental Assembly 6 = RoHS 6/6*
		G	JTAG 0 - Not Installed* 1 - Installed

* Default

† Contact Sky Blue or Zerif for availability

DS-A5PL | Rev 2018.11.15 | November 2018

Contact



Sky Blue Microsystems GmbH
Geisenhausenerstr. 18
81379 Munich, Germany
+49 89 780 2970, info@skyblue.de
www.skyblue.de



In Great Britain:
Zerif Technologies Ltd.
H5 Ash Tree Court
Nottingham NG8 6PY, England
+44 115 855 7883, info@zerif.co.uk
www.zerif.co.uk