

Proc10M

Ultra-High Performance Stratix10MX HBM2 Module



Key Features

- Large HBM2 FPGA with ultra-compact module (97.4mm x 101mm / 3.83" x 3.98")
- Flexible usage via customized carrier board or via Gidel's carrier board
- Stratix 10MX 2100 HBM2 FPGA:
 - 2,073,000 LEs
 - 7,920 18 x 19 MAC
- 5-level memory scheme (50TB/s+):
 - 400 GB/s access to DRAM
 - 90 GB/s access to SRAM
 - Max capacity > 128 GB
 - ✓ 8/16GB on module
 - ✓ up to 128GB on carrier
- 72 Transceivers with bandwidth > 1,600 Gb/s (TX+RX):
 - 48 x up to 26 Gb/s
 - 16 x up to 16 Gb/s or PCIe Gen3x16
 - 8 x up to 16Gb/s
 - Option for 64 x up to 26 Gb/s
- 374 I/Os supporting:
 - 26 x 3.3V IOs
 - 96 x LVDS (1.6Ghz/line)
 - 72 bit DDR4 interface
- PLLs with jitter cleaners(100fs)
- 10 dedicated input reference clocks
- 2 x output reference clock
- Supports up to 120W (@12V)
- Active or passive cooling
- May be used on half-length PCIe carrier board
- Supported by Gidel Proc Dev Kit (via a PCIe carrier)

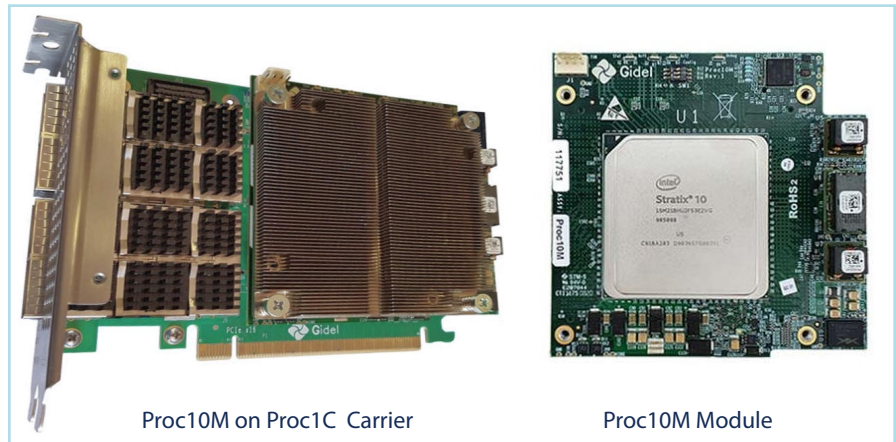

The Stratix10 MX offers 10X more DRAM and SRAM bandwidth than discrete DDR4 and QDR memories. Gidel's Proc10M module is designed to enable easy use and immediate accessibility to this powerful technology for computer-based, embedded systems and edge computing.

The combination of the Proc10M's large FPGA, huge memory bandwidth and 1,600 Gb/s IOs enables unprecedented level of processing, system compactness and cost performance. The powerful Proc10M opens the way to implement diverse innovations and high-end applications, including:

- Compact **Broadcast** and **Image-Processing** solutions enabling to grab data from multiple fast edge sensors and to perform image enhancements, processing, recognition, compression and AI inferences.
- **5G** and **Radar** combining high-speed digital I/O interfaces and edge computing such as FFTs to selectively reduce data and offload it via PCIe x16 or dedicated links.
- **Ultra-fast switch** for wireline traffic management up to 800G and single device solution for Deep Packet Inspection (DPI)
- **AI training** leveraging 128GB density, HBM2s' huge bandwidth and the FPGA's massive logic and DSP blocks.

High-end solutions can be achieved within remarkable short time using the Proc10M module, Gidel/user carrier boards and Gidel's powerful development suite, thus significantly accelerating the time to market and improving the ROI.

Proc10M - Ultra-High Performance Stratix10MX Module



Proc10M Carrier Boards

The Proc10M module has been designed for use with carrier boards to enable tailoring solutions that significantly reduce risks, costs and time to market. User carriers may incorporate any combination of Rx, Tx or full duplex transceivers. Gidel's off-the-shelf carrier board can be used as is for deployment or as a reference design thus further improving the ROI. Gidel's Proc1C half-length PCIe carrier includes PCIe Gen. 3 x16, 4 xQSFP28, PHS and GPIOs. The PHS interface enables connecting board-to-board or mounting a daughter board such as Gidel's 8 xCoaXPress 12.

Proc Dev Kit

- Significantly reduces development time and cost while preserving optimized performance.
- Enables immediate building of ASP (Application Support Package) optimized to the system requirements by mapping the board resources to the application needs.
- Enables parallel access of multiple applications on a single FPGA thus expediting the development and improving system reliability. For example, firewall and compression may be accelerated simultaneously on the same FPGA and controlled by independent applications.

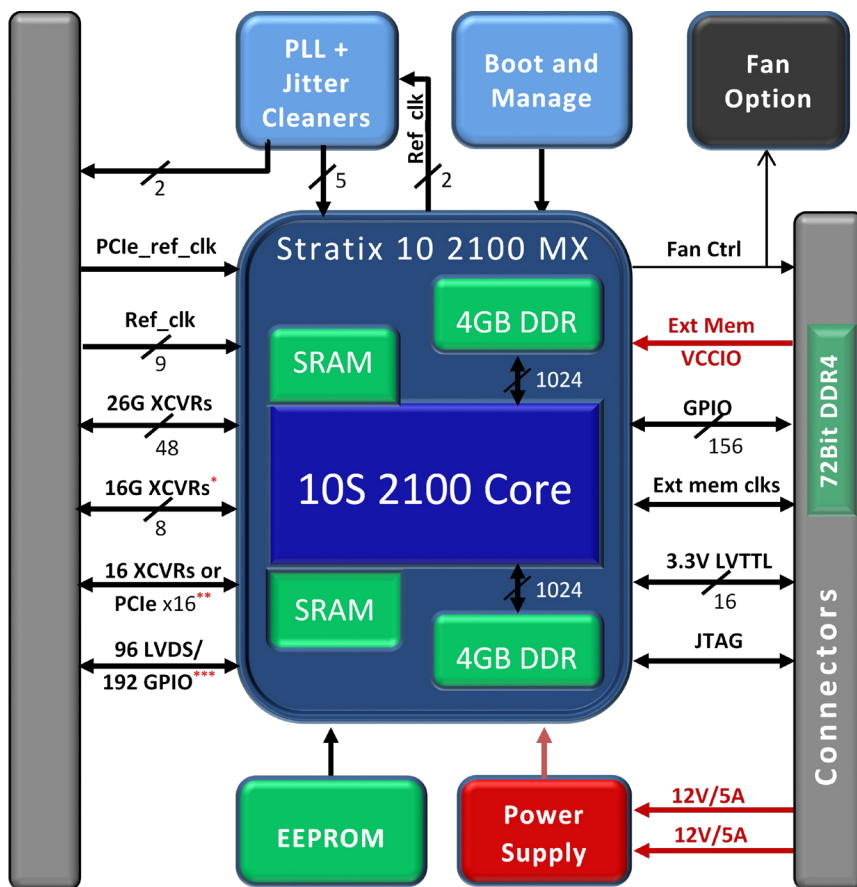

Proc10M Block Diagram

- * Option for 5 x 26G or 8 x 16G
- ** Option for 11 x 26G, 16 x 16G or 16 x PCIe Gen. 3
- *** Design may implement a combination of LVDSs and GPIOs

Name	Units	Total Capacity	Max Total Throughput
MLAB	17K	11Gb	50 TB/s
M20K	16.8K	134 Gb	41 TB/s
eSRAM	2	94.5Mb	90 GB/s
HBM2 DDR	2	8GB	400 GB/s
DDR4 on carrier board	1	Up to 128GB with ECC	15 GB/s

Memory Performance

International Distributors



Sky Blue Microsystems GmbH
Geisenhausenerstr. 18
81379 Munich, Germany
+49 89 780 2970, info@skyblue.de
www.skyblue.de



In Great Britain:
Zerif Technologies Ltd.
Winnington House, 2 Woodberry Grove
Finchley, London N12 0DR
+44 115 855 7883, info@zerif.co.uk
www.zerif.co.uk