



## Iron CLHS 252

# Iron CLHS

## Small Form Factor, Ruggedized Camera

### Innovative Approach

The **Iron CLHS 252** is a compact, high speed, low-cost, low-power global shutter CMOS camera with a CLHS interface which supports 3.15 MP high quality video at rates up to 205.8 fps.

### Intelligent Design

Our camera incorporates Pregius's IMX252 global shutter sensor with a 3.45 $\mu$ m pixel size. With an extremely compact outline and low-key design, the **Iron** can be fitted into tight spaces. Superior sensor performance allows very low light vision capabilities.

### Applications:

- Perimeter vision
- Low light surveillance
- Special Effects
- Virtual Reality
- 3D

### Key Features:

- 3.15 Megapixel up to 205.8 fps
- Monochrome and Color models
- Up to 4.5W power at full rate
- Full image processing feature set
- Optional Pan/Tilt alignment of the sensor
- CLHS X-Protocol 10Gpbs fiber optic interface
- C / CS / EF or DC Auto Iris mounts available
- Full EMVA1288 report
- Full built-in self-test (BIT)
- Full built-in voltage testing
- Customization as per user requirements

## Specifications

Feature	Description
Pixel Size	3.45 μm x 3.45 μm
Resolution	2048 (H) x 1536 (V)
Sensor Size	8.9 mm diagonal
Sensor	Sony Pregius IMX252 CMOS sensor
Output Interface	Fiber 10Gbps: CLHS (X-protocol). 10GiGE Vision is available upon request.
Interface Connector	Fiber optic SFP+ module (single mode 1310nm)
Supported SFP+ Modules	<ul style="list-style-type: none"> <li>▪ Single-mode 1310nm</li> <li>▪ Multi-mode 850nm</li> <li>▪ Bidirectional single-mode (single fiber)</li> <li>▪ CWDM</li> </ul>
Output Resolution	8, 10 or 12 bit
Max Frame Rate	205.8 fps @8 bit resolution 112.3 fps @10 bit resolution 112.3 fps @12 bit resolution
Image Acquisition	Continuous / Triggered
Camera Control	GenCam
Electronic Shutter	Global shutter
Sensor Positioning	Full pan/tilt calibration for optical axes <b>(optional)</b>
Monochrome/ Color	Monochrome / Color
Temporal Noise	< 2.2 e <sup>-</sup> @25°C
Full Well Charge	9828 e <sup>-</sup>
Dynamic Range	> 70.8dB @520nm
Signal-to-Noise Ratio (SNR max)	40 dB @520nm
Quantum Efficiency (QE) X FF	> 63% @525nm
Shortest Exposure	10 μs
On Camera Processing	<ul style="list-style-type: none"> <li>▪ Defect pixel correction</li> <li>▪ ROI</li> <li>▪ Frame counter</li> <li>▪ Flat field / Fixed pattern noise correction</li> <li>▪ Auto/Manual black level</li> <li>▪ Auto Exposure/Gain</li> <li>▪ Auto/Manual White balance</li> <li>▪ Image flip</li> <li>▪ LUT</li> <li>▪ Gain (Analog / Digital)</li> <li>▪ Binning</li> <li>▪ Operational Time Counter</li> </ul>
GPIO Connection	Two inputs, two outputs, external trigger & strobe controller

## Mechanical & Electrical

Feature	Description
Dimensions (including lens mount)	45.8 mm x 45.8 mm x 86.8 mm (Height x Width x Depth)
Lens Mount	C-mount, CS-mount, EF-mount or DC Auto Iris lenses
Weight (without lens)	<180g
Power Input	12V (optional 5 – 36V)
Power Consumption	<4.5W @ 12V DC
Operating Temperature	-40°C to 80°C (-40°C to 70°C for 10GiGE), 20-85% humidity (non-condensing)
Storage Temperature	-40°C to 85°C (-40°C to 75°C for 10GiGE), 10-90% humidity (non-condensing)
Ingress Protection	Optional IP67 (with protective lens tube)
Operational Shock	Tested per MIL-STD-810G Method 516.6, 3-axis Shock 75G
Operational Vibration	Tested per MIL-STD-810G Method 514.6, 3-axis Vibration Category 20

\* KAYA Instruments reserves the right to update the data sheet from time to time without prior notice.

# General Purpose Input Output

GPIO Pinout – 12 Pin Hirose Connector

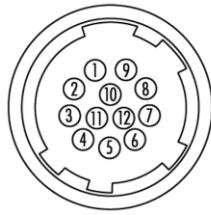

- |                    |                 |
|--------------------|-----------------|
| 1. 5 VDC Return    | 7. OUT1 (TTL)   |
| 2. +5 VDC          | 8. IN1 (OPTO)   |
| 3. Reserved        | 9. IN2 (LVTTTL) |
| 4. Reserved        | 10. IN1 RTN     |
| 5. OUT2 RTN (OPTO) | 11. IN2 RTN     |
| 6. OUT1 RTN        | 12. OUT2 (OPTO) |

## Absolute Quantum Efficiency

Pregius's IMX252 Mono Spectral Response

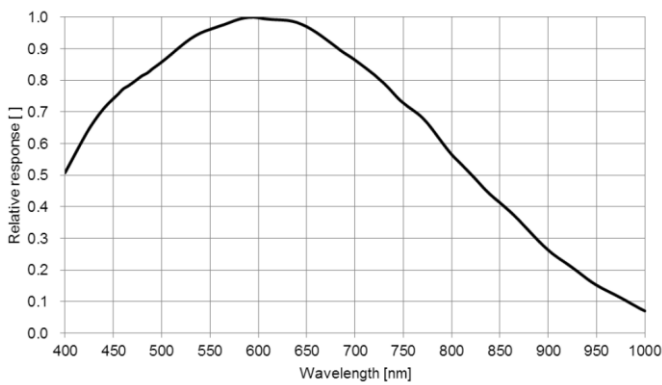

Pregius's IMX252 Color Spectral Response

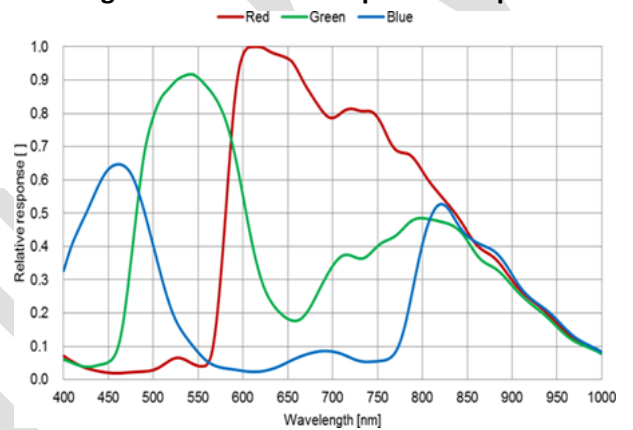

## Mechanical Drawings

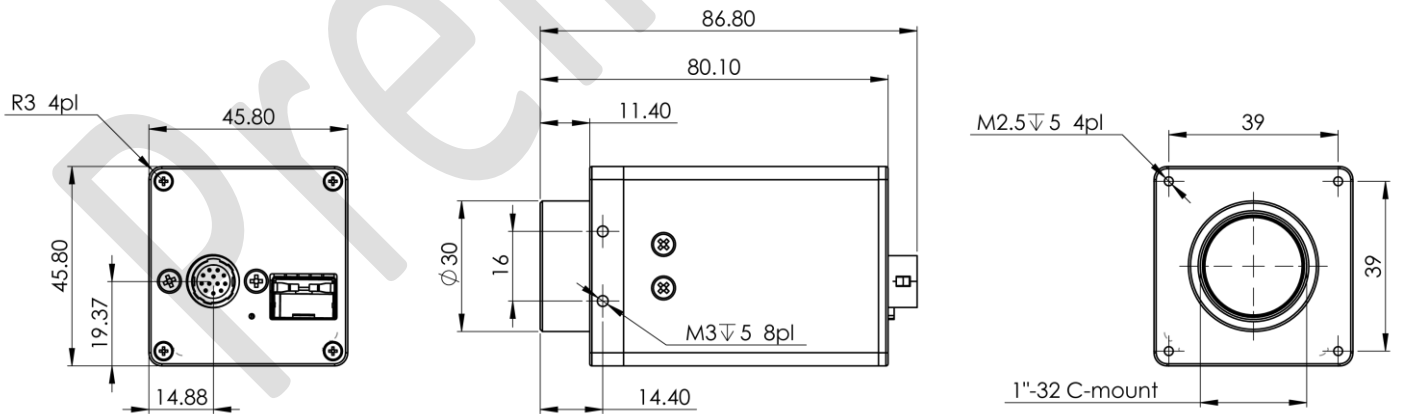

## Compatibility

**KAYA Instruments** creates and maintains compatibility and interfaces for the most common and advanced vision image processing libraries and applications. Major support is available for **MVTec Halcon**, **National Instruments' LabVIEW** and **MathWorks' MATLAB**.

❖ Supported vision standards:



❖ Supported vision libraries:



❖ Supported operating systems:



*Please check our website for an up-to-date list of other supported libraries and software package*

## Contact Us

International Distributors



Sky Blue Microsystems GmbH  
Geisenhausenerstr. 18  
81379 Munich, Germany  
+49 89 780 2970, info@skyblue.de  
www.skyblue.de



In Great Britain:  
Zerif Technologies Ltd.  
Winnington House, 2 Woodberry Grove  
Finchley, London N12 0DR  
+44 115 855 7883, info@zerif.co.uk  
www.zerif.co.uk