



Iron CLHS 305

Iron CLHS Small Form Factor, Ruggedized Camera

Innovative Approach

The **Iron CLHS 305** is a compact, high speed, low-cost, low-power global shutter CMOS camera with a CLHS interface which supports 8.85 MP high quality video at rates up to 62.5 fps.

Intelligent Design

Our camera incorporates Pregius's IMX255 global shutter sensor with a 3.45 μ m pixel size. With an extremely compact outline and low-key design, the **Iron** can be fitted into tight spaces. Superior sensor performance allows very low light vision capabilities.

Applications:

- Perimeter vision
- Military/Defense systems
- Low light surveillance
- Special Effects
- Virtual Reality
- 3D

Key Features:

- 8.85 Megapixel up to 62.5 fps
- Monochrome and Color models
- Up to 4.5W power at full rate
- Full image processing feature set
- Optional Pan/Tilt alignment of the sensor
- CLHS X-Protocol 10Gpbs fiber optic interface
- C / CS / EF or DC Auto Iris mounts available
- Full EMVA1288 report
- Full built-in self-test (BIT)
- Full built-in voltage testing
- Customization as per user requirements

Specifications

Feature	Description
Pixel Size	3.45 μm x 3.45 μm
Resolution	4112 (H) x 2160 (V)
Sensor Size	16.0 mm diagonal
Sensor	Sony Pregius IMX305 CMOS sensor
Output Interface	Fiber 10Gbps: CLHS (X-protocol). 10GiGE Vision is available upon request.
Interface Connector	Fiber optic SFP+ module
Supported SFP+ Modules	<ul style="list-style-type: none"> ▪ Single-mode 1310nm ▪ Multi-mode 850nm ▪ Bidirectional single-mode (single fiber) ▪ CWDM
Output Resolution	12 bit
Max Frame Rate	62.58 fps
Image Acquisition	Continuous / Triggered
Camera Control	Gen<i>Cam
Electronic Shutter	Global shutter
Sensor Positioning	Full pan/tilt calibration for optical axes (optional)
Monochrome/ Color	Monochrome / Color
Temporal Noise	< 2.2 e^- @25°C
Full Well Charge	9828 e^-
Dynamic Range	> 70.8dB @520nm
Signal-to-Noise Ratio (SNR max)	40 dB @520nm
Quantum Efficiency (QE) X FF	> 63% @525nm
Shortest Exposure	10 μs
On Camera Processing	<ul style="list-style-type: none"> ▪ Defect pixel correction ▪ ROI ▪ Frame counter ▪ Flat field / Fixed patter noise correction ▪ Auto/Manual black level ▪ Auto Exposure/Gain ▪ Auto/Manual White balance ▪ Image flip ▪ LUT ▪ Gain (Analog / Digital) ▪ Binning ▪ Operational Time Counter
GPIO Connection	Two inputs, two outputs, external trigger & strobe controller

Mechanical & Electrical

Feature	Description
Dimensions (including lens mount)	45.8 mm x 45.8 mm x 86.8 mm (Height x Width x Depth)
Lens Mount	C-mount, CS-mount, EF-mount or DC Auto Iris lenses
Weight (without lens)	<180g
Power Input	12V (optional 5 – 36V)
Power Consumption	<4.5W @ 12V DC
Operating Temperature	-40°C to 80°C (-40°C to 70°C for 10GiGE), 20-85% humidity (non-condensing)
Storage Temperature	-40°C to 85°C (-40°C to 75°C for 10GiGE), 10-90% humidity (non-condensing)
Ingress Protection	Optional IP67 (with protective lens tube)
Operational Shock	Tested per MIL-STD-810G Method 516.6, 3-axis Shock 75G
Operational Vibration	Tested per MIL-STD-810G Method 514.6, 3-axis Vibration Category 20

* KAYA Instruments reserves the right to update the data sheet from time to time without prior notice.

General Purpose Input Output

GPIO Pinout – 12 Pin Hirose Connector

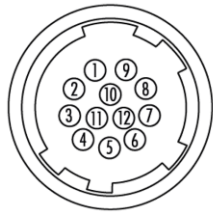

- | | |
|--------------------|-----------------|
| 1. 5 VDC Return | 7. OUT1 (TTL) |
| 2. +5 VDC | 8. IN1 (OPTO) |
| 3. Reserved | 9. IN2 (LVTTTL) |
| 4. Reserved | 10. IN1 RTN |
| 5. OUT2 RTN (OPTO) | 11. IN2 RTN |
| 6. OUT1 RTN | 12. OUT2 (OPTO) |

Absolute Quantum Efficiency

Pregius's IMX305 Mono Spectral Response

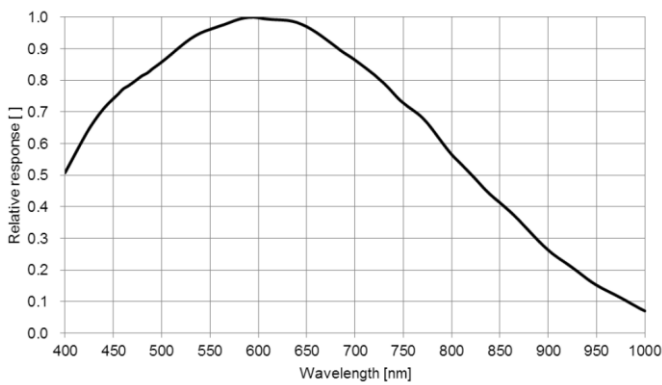

Pregius's IMX305 Color Spectral Response

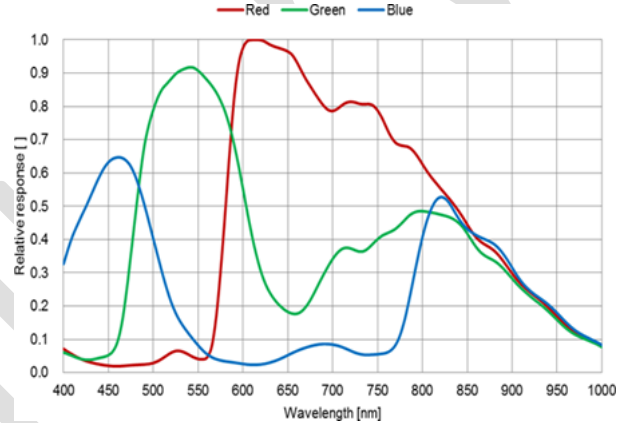

Mechanical Drawings

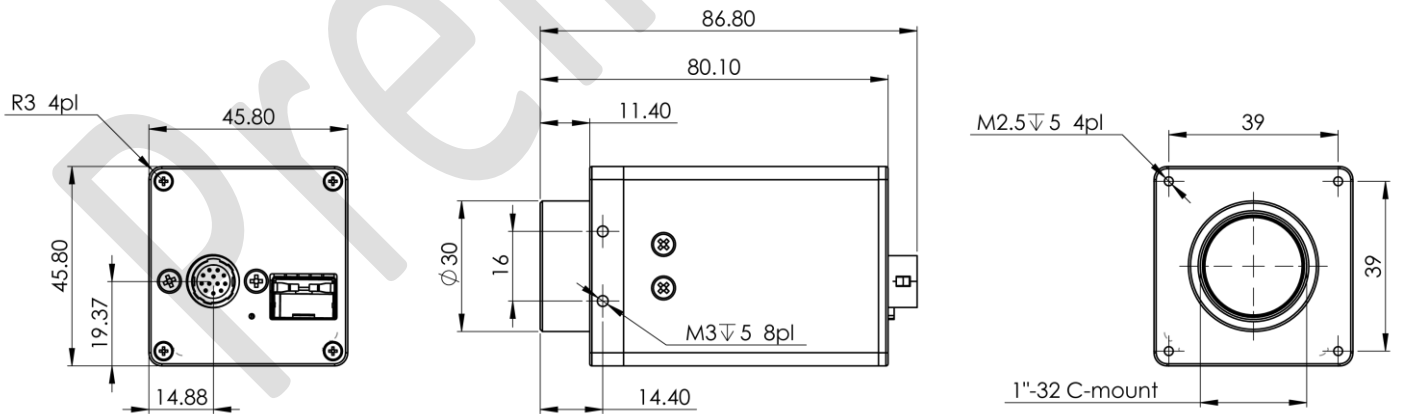

Compatibility

KAYA Instruments creates and maintains compatibility and interfaces for the most common and advanced vision image processing libraries and applications. Major support is available for **MVTec Halcon**, **National Instruments' LabVIEW** and **MathWorks' MATLAB**.

❖ Supported vision standards:



❖ Supported vision libraries:



❖ Supported operating systems:



Please check our website for an up-to-date list of other supported libraries and software package

International Distributors



Sky Blue Microsystems GmbH
Geisenhausenerstr. 18
81379 Munich, Germany
+49 89 780 2970, info@skyblue.de
www.skyblue.de



In Great Britain:
Zerif Technologies Ltd.
Winnington House, 2 Woodberry Grove
Finchley, London N12 0DR
+44 115 855 7883, info@zerif.co.uk
www.zerif.co.uk