

High Speed Mezzanine Card (HSMC) to FPGA Mezzanine Card (FMC) adapter board (KY-HSMC2FMC)

Overview

The HSMC2FMC is an adapter board designed to enable connection of industry standard FMC cards to Altera boards with HSMC interface. This adapter board is designed to support full duplex high speed serial signals (SerDes), as well as LVDS or single ended signals. The HSMC2FMC uses a standard HSMC connector as an interface to the host board and standard HPC connector as an interface to mezzanine card.

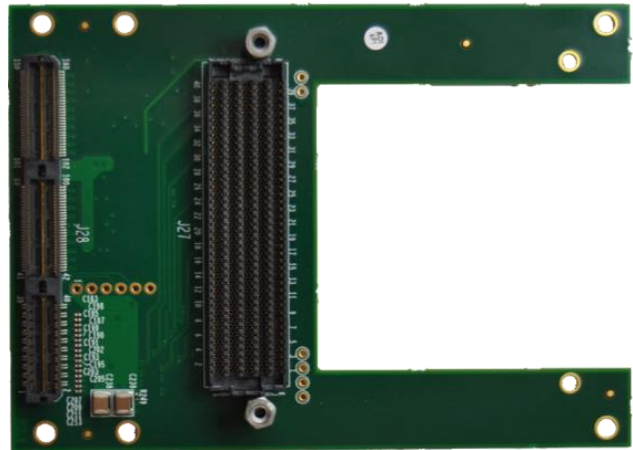

About FMC

FPGA mezzanine card, or FMC, as defined in VITA 57.1, provides a specification describing an I/O mezzanine module with connection to an FPGA or other device with reconfigurable I/O capability. The FMC standard describes a versatile module, which can target a range of applications, environments, and markets. The specification defines a commercial grade version, which extends to cover a ruggedized conduction variant. FPGA's provide a high pin count that can operate at many Gbps. The latest connector technology is defined to maintain the high performance interface from the I/O on the mezzanine module, to the FPGA on the carrier card. The FMC mezzanine module design minimizes design effort and resources through minimal system support and flexible pin allocation.



About HSMC

The Altera high speed mezzanine card (HSMC) specification defines the electrical and mechanical properties of a high speed mezzanine card adapter interface for FPGA-based motherboards. This specification should allow for the design of interoperable motherboards and add-on cards by different manufacturers that can interoperate and utilize the high-performance I/O features found in today's FPGA devices.



Features

- Enables connection of standard FMC cards to Altera FPGA carrier boards
- Interfaces:
 - Up to 8 full duplex high speed serial channels with HPC
 - Up to 1 full duplex high speed serial channels with LPC
 - Up to 34 LVDS channels or 68 single ended LVTTTL signals connected to FMC connector
- Altera HSMC compliant
- FMC (VITA 57.1) compliant
- Support HPC or LPC FMC
- Supports air and conduction cooling FMC
- Selectable VADJ voltage (1.5V, 1.8V, 2.5V and 3.3V)
- 78mm x 110mm, single slot HSMC, single slot FMC
- -40°C to 85°C operating environment temperature (industrial grade)

Deliverables

- KY-HSMC2FMC
- Hardware user manual

Applications

- ✓ Analog to digital conversion
- ✓ Digital to analog conversion
- ✓ Interface peripherals (HD/SD/SDI/SFP/PCIe/SMA etc.)
- ✓ Serial connectivity (LVDS/Serdes etc.)
- ✓ Image processing (HDMI/ DVI/ DP/ LVDS etc.)
- ✓ Machine vision (CameraLink/CXP etc.)
- ✓ Industrial interfaces

HSMC2FMC Block Diagram

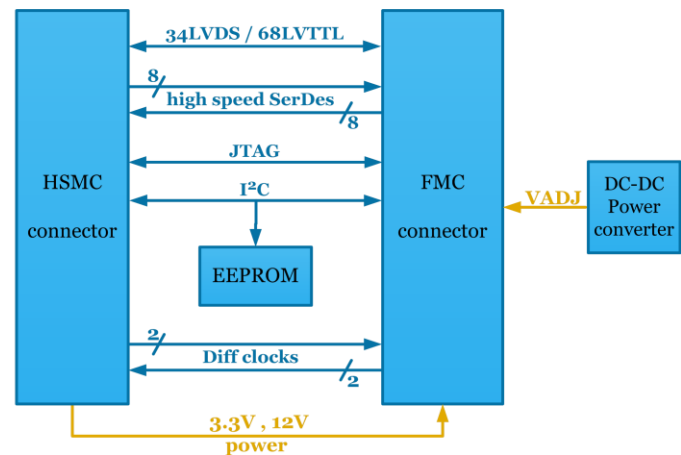

Contact



Sky Blue Microsystems GmbH
Geisenhausenerstr. 18
81379 Munich, Germany
+49 89 780 2970, info@skyblue.de
www.skyblue.de



In Great Britain:
Zerif Technologies Ltd.
H5 Ash Tree Court
Nottingham NG8 6PY, England
+44 115 855 7883, info@zerif.co.uk
www.zerif.co.uk